

# WOLF WALL MOUNTED GAS CONDENSING BOILERS COMFORTLINE

CGB-2(K) / CGW-2 / CGS-2L / CGS-2R / CSZ-2  
UP TO 24 KW

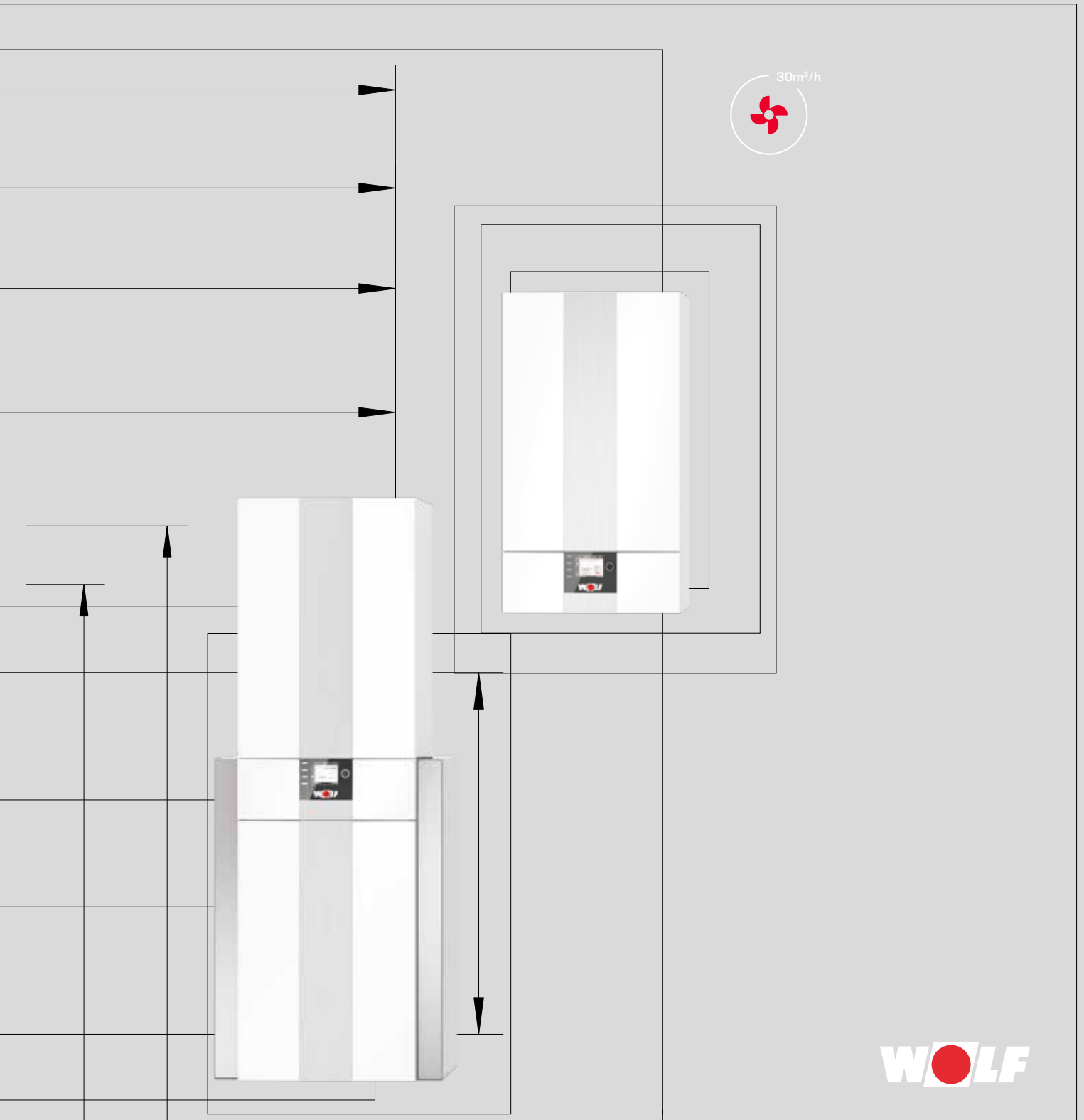

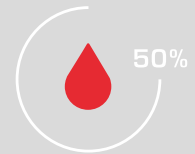
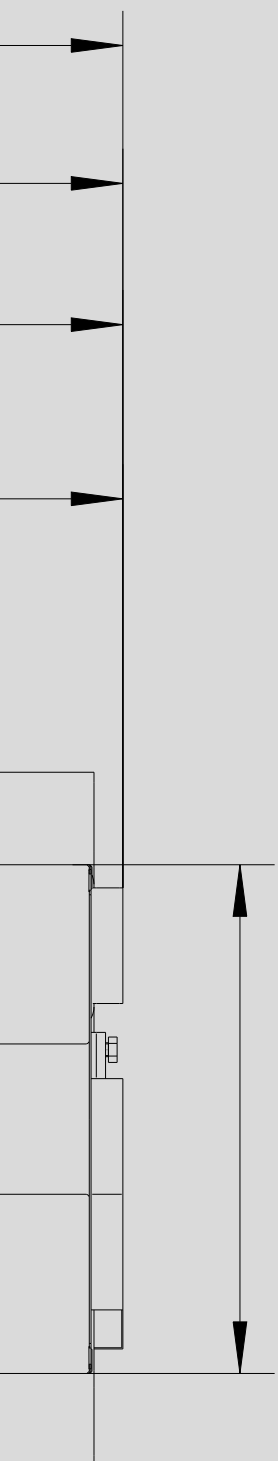

## THE EXTENSIVE EQUIPMENT RANGE

from system supplier WOLF offers the ideal solution for commercial and industrial buildings, new build and modernisation projects alike.

The range of WOLF control units can meet any requirement for heating convenience.

All equipment is easy to operate, highly energy efficient and reliable.

Solar thermal systems can be swiftly integrated into existing systems.

WOLF equipment is easy and quick to install and maintain.

<b>COMFORTLINE GAS CONDENSING BOILERS</b>	<b>CGB-2</b>	04-05
	<b>CGB-2(K)</b>	06
	<b>CSW-120</b>	06
	<b>CGW-2</b>	07
	<b>CGS-2L</b>	08
	<b>CGS-2R</b>	09
	<b>CSZ-2</b>	10-11
<b>SPECIFICATION</b>	<b>CGB-2 / CGB-2(K)</b>	12-13
	<b>CGW-2</b>	14-15
	<b>CGS-2L</b>	16-17
	<b>CGS-2R</b>	18-19
	<b>CSZ-2</b>	20-21
	<b>CSW-120</b>	22-23
<b>STANDARD CONTROL UNIT</b>		24
<b>CONTROL ACCESSORIES</b>		25-27
<b>AIR/FLUE GAS ROUTING</b>		28-29
<b>ACCESSORIES</b>		30-32

Gas condensing boilers, sealed combustion chamber,  
for room sealed or  
open flue operation

High standard seasonal efficiency [to DIN]  
up to 110 % [net cv] / 99 % [gross cv] for  
the best possible energy efficiency

Meets the requirements for the "Blue Angel" eco-label  
according to RAL-UZ 61 when operated with natural gas

Premix burner for natural gas  
E, LL and LPG, variable modulating  
heating output from 1.8 kW

With expansion vessel,  
modulating high efficiency pump  
[EEI ≤ 0.20] and 3-way valve as standard

Appliance converts automatically  
to a different gas type without  
conversion kit or resetting  
of the control unit

Automatic CO2 setting  
with self-calibrating combustion air controller  
for extremely clean combustion

Optimum utilisation of condensing technology  
by controlling the spread without an overflow valve;  
no return temperature raising required

Heating water heat exchanger  
can be pivoted under system pressure  
for maintenance without having to  
drain the heating water

WOLF "ALUPro" coated  
heating water  
heat exchanger

**Communication**  
via smartphone, laptop or PC

**WOLF WRS-2 control system**  
can be set and operated via smartphone or PC

**Cascadable**  
up to 120 kW

17

## **BENEFITS OF WOLF GAS CONDENSING BOILERS UP TO 24 KW**

CGB-2(K) / CGW-2 / CGS-2 / CSZ-2

**Hybrid-capable**  
Ready to be intelligently combined with WOLF heat pumps

**Efficient combustion technology**  
with gas-adaptive self-calibrating  
combustion controller that adjusts  
automatically to the prevailing  
gas quality

**Easy flue gas emissions testing**  
from outside without opening the appliance

**Convenient access to all components**  
for quick installation and  
easy operation and maintenance



FLIP &  
CLEAN



SMARTSET



MADE IN  
GERMANY  
BY WOLF



HYBRID



COMFORTLINE GAS CONDENSING BOILERS

## CGB-2-14, -20, -24

### GAS CONDENSING BOILER FOR HEATING

with option to connect a DHW cylinder,  
e.g. CSW-120

#### MODULATION RANGE

for flow / return 50 / 30 °C

#### BOOSTER OUTPUT

for cylinder heating

CGB-2-14	from 2.1 to 15.2 kW		
CGB-2-20	from 4.4 to 20.4 kW	CGB-2-20	22.2 kW
CGB-2-24	from 5.6 to 25.8 kW	CGB-2-24	27.1 kW

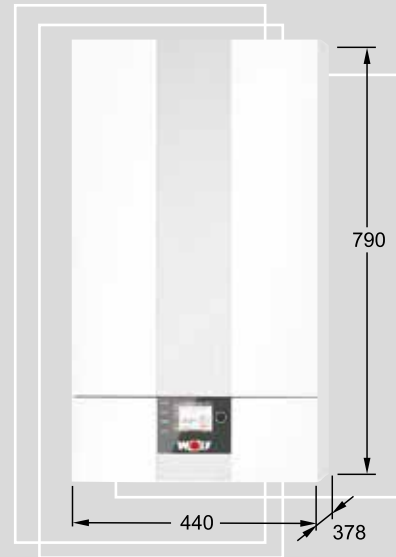

## CGB-2K-20, -24

### GAS CONDENSING BOILER FOR HEATING AND DHW

- with integral stainless steel DHW heat exchanger
- for demand-dependent, hygienic DHW heating
- precise flow control ensures constant draw-off temperature

#### MODULATION RANGE

for flow / return 50 / 30 °C

#### BOOSTER OUTPUT

for DHW heating

CGB-2K-20	from 4.4 to 20.4 kW	CGB-2K-20	22.2 kW
CGB-2K-24	from 5.6 to 25.8 kW	CGB-2K-24	27.1 kW

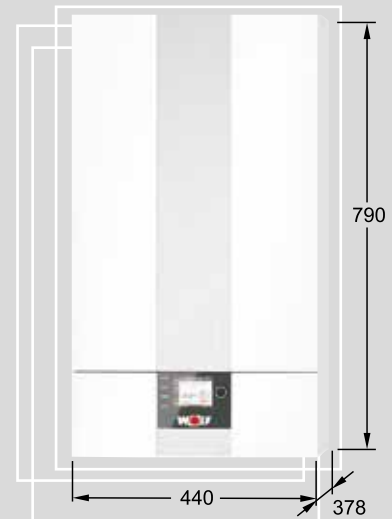

## CSW-120

### DHW CYLINDER



Cleaning aperture and R<sup>3</sup>/<sub>4</sub>" connections for flow, return, cold water, hot water and DHW circulation at the top of the cylinder for easy pipework connection and cleaning

White RAL 9016 / powder-coated casing

Rigid PUR foam thermal insulation all around the cylinder, applied directly to the cylinder surface, highly effective for low heat losses

Corrosion protection through enamelled cylinder interior and internal indirect coil to DIN 4753, Part 3. Additional corrosion protection through sacrificial magnesium anode integrated into the inspection and cleaning aperture

Internal indirect coil with large heat exchanger surface area for short heat-up times

High continuous DHW output thanks to generously sized indirect coil

R<sup>1</sup>/<sub>2</sub>" drain outlet at the front, incl. drain valve and hose fitting

Adjustable feet

5 year statutory warranty

**CGW-2-14/100L, -20/120L, -24/140L**  
**GAS CONDENSING CENTRE WITH HIGH PERFORMANCE**  
**STAINLESS STEEL STRATIFICATION CYLINDER**

Wall mounted gas condensing centre, comprising a wall mounted gas condensing boiler with a stainless steel DHW heat exchanger and a stainless steel stratification cylinder in modular design

**MODULATION RANGE**  
 for flow / return 50 / 30 °C

**BOOSTER OUTPUT**  
 for stratification cylinders

CGW-2-14/100L	from 2.1 to 15.2 kW	
CGW-2-20/120L	from 4.4 to 20.4 kW	CGW-2-20/120L 22.2 kW
CGW-2-24/140L	from 5.6 to 25.8 kW	CGW-2-24/140L 27.1 kW

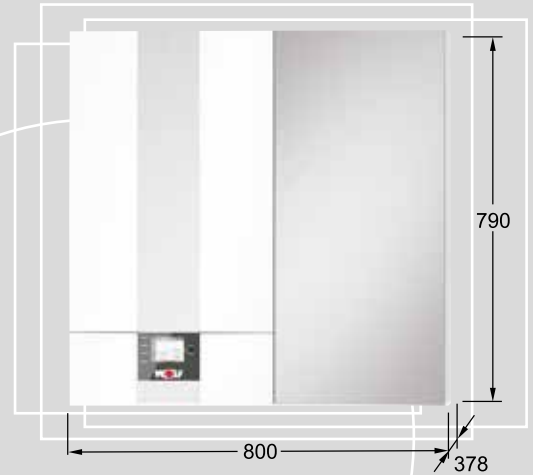

Integral and convenient DHW heating - better than a DHW cylinder (with indirect coil) with 100, 120 or 140 l capacity

Controlled cylinder heating for optimum energy efficiency through the effective utilisation of condensing technology [European patent granted]

"DHW turbo" with a stainless steel routing and distribution system for hot and cold water ensures quiet, radial water distribution and excellent DHW output [european patent pending]

Compact layout as condensing boiler with attached stratification cylinder ensures very low installation costs

With the CGW-2-14/100L, filling a bath tub with around 140 l of water at 40 °C only takes 10 minutes

Gas condensing centre is fully wired and ready to connect to the water system

High savings on operating costs through efficient DHW heating and innovative insulation technology with integral annular gap system (utility model protection)

Can be split quickly and easily into two transportable modules weighing 35 kg and 19 kg for straightforward installation

**THE FOLLOWING ACCESSORIES ARE AVAILABLE TO ENSURE QUICK AND CLEAN INSTALLATION:**

DHW connection set with pressure reducer for concealed installation / surface mounting

DHW connection set without pressure reducer for concealed installation / surface mounting

Solar connection set

Pipe cladding

Disconnection point heating module / stratification cylinder

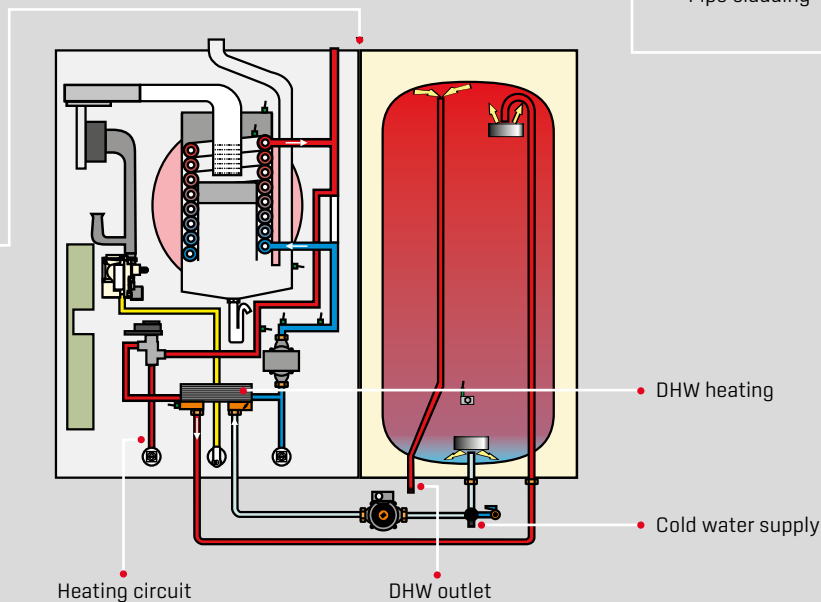

**CGS-2-14/120L, -20/160L, -24/200L**  
**GAS CONDENSING CENTRE WITH STAINLESS STEEL DHW HEAT EXCHANGER AND ENAMELLED STEEL STRATIFICATION CYLINDER**

Gas condensing centre, comprising a wall mounted gas condensing boiler with a stainless steel DHW heat exchanger and a stratification cylinder in modular design

**MODULATION RANGE**  
 for flow / return 50 / 30 °C

**BOOSTER OUTPUT**  
 for DHW heating

CGS-2-14/120L	from 2.1 to 15.2 kW		
CGS-2-20/160L	from 4.4 to 20.4 kW	CGS-2-20/160L	22.2 kW
CGS-2-24/200L	from 5.6 to 25.8 kW	CGS-2-24/200L	27.1 kW

The "Turbostop system" provides convenient DHW heating inside the stratification cylinder - better than a DHW cylinder (with indirect coil) with 120, 160 or 200 l capacity

High output factor  $N_L = 1.3$  or  $2.5$  for heating from 10 °C to 60 °C

Controlled cylinder heating for optimum energy efficiency through the effective utilisation of condensing technology (European patent granted)

Minimal heat losses thanks to highly efficient insulation technology - just 1.0 kWh standby loss in 24 hours

With the CGS-2-20/160L, filling a bath tub with around 230 l of water at 40 °C only takes 10 minutes; the CGS-2-14/120L fills a bath with around 190 l of water at 40 °C in the same time

Compact layout as a wall mounted condensing boiler with stratification cylinder. Can be split easily into two modules of 35 kg and 49 kg respectively for easy installation

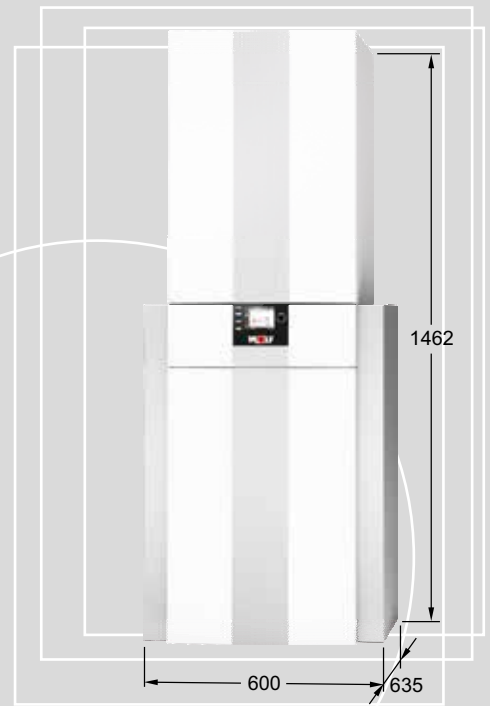

**THE FOLLOWING ACCESSORIES ARE AVAILABLE TO ENSURE QUICK AND CLEAN INSTALLATION:**

Pipework connection set with flexible stainless steel pipes and thermal insulation, suitable for surface mounting or concealed installation

Solar connection set for the additional control of a solar cylinder

Drain outlet kit with triple hose retainer

Pipework cladding with variable knock-out entries

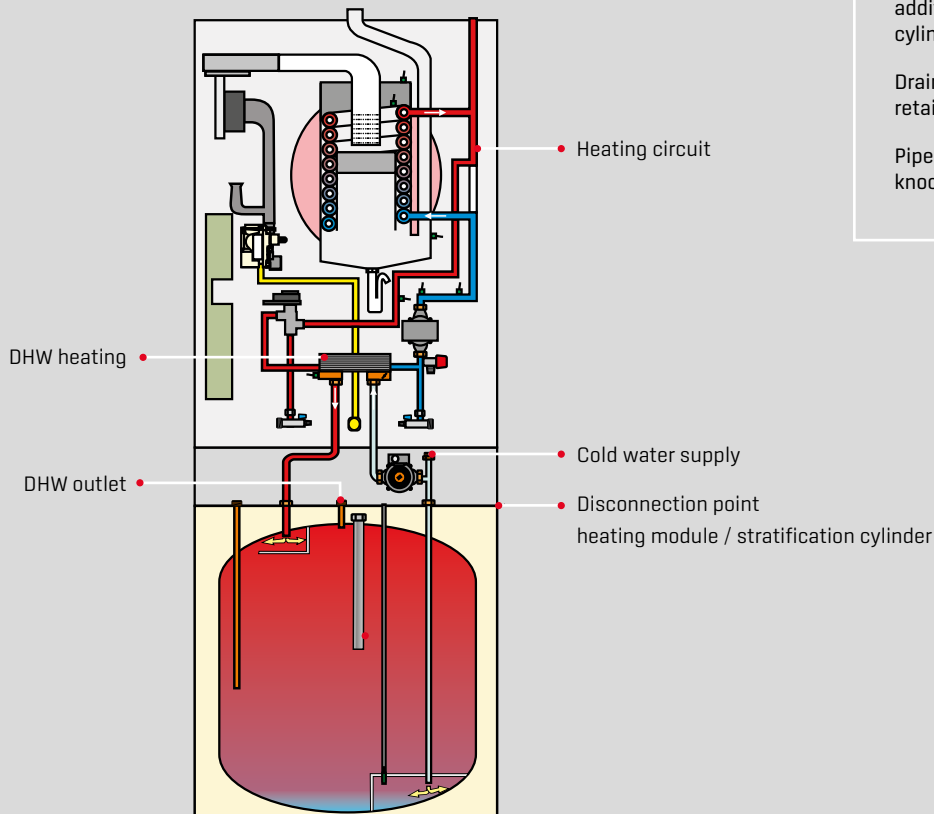



## CGS-2-14/150R, -20/150R, -24/150R GAS CONDENSING CENTRE WITH ENAMELLED STEEL DHW CYLINDER WITH INDIRECT COIL

Gas condensing centre, comprising a wall mounted gas condensing boiler and DHW cylinder with indirect coil in a modular design

**MODULATION RANGE**  
for flow / return 50 / 30 °C

**BOOSTER OUTPUT**  
for DHW heating

CGS-2-14/150R	from 2.1 to 15.2 kW		
CGS-2-20/150R	from 4.4 to 20.4 kW	CGS-2-20/150R	22.2 kW
CGS-2-24/150R	from 5.6 to 25.8 kW	CGS-2-24/150R	27.1 kW

Controlled cylinder heating for optimum energy efficiency through the effective utilisation of condensing technology (European patent granted)

Minimal heat losses thanks to highly efficient insulation technology - just 1.47 kWh standby loss in 24 hours

With the CGS-2-20/150R, filling a bath tub with around 230 l of water at 40 °C only takes 10 minutes; the CGS-2-14/150R fills a bath with around 210 l of water at 40 °C in the same time

Compact design as condensing boiler and DHW cylinder with indirect coil. Can be split easily into two modules of 35 kg and 80 kg respectively for easy installation

High output factor  $N_L = 1.4$  or 1.8 for heating from 10 °C to 60 °C

Cylinder heating via robust internal indirect coil with generously sized heat exchanger surface area for short heat-up times

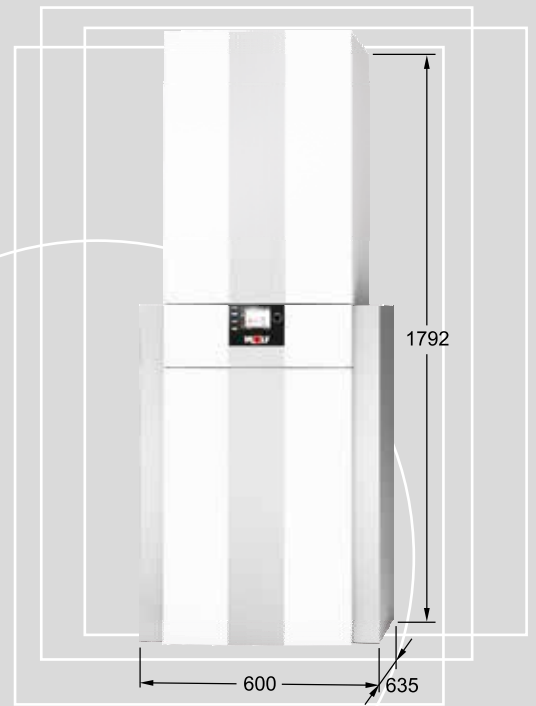

THE FOLLOWING ACCESSORIES ARE AVAILABLE TO ENSURE QUICK AND CLEAN INSTALLATION:

Pipework connection set with flexible stainless steel pipes and thermal insulation, suitable for surface mounting or concealed installation

Solar connection set for the additional control of a solar cylinder

Drain outlet kit with triple hose retainer

Pipework cladding with variable knock-out entries

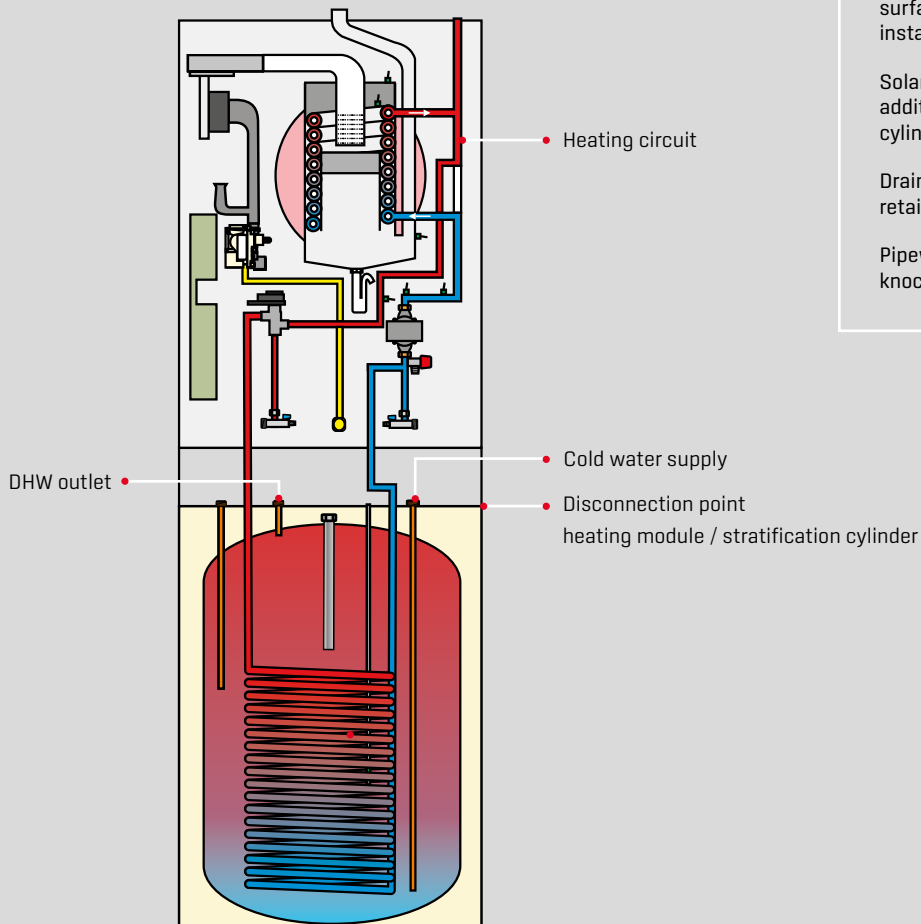

## CSZ-2-14/300R, -20/300R, -24/300R

### GAS CONDENSING SOLAR CENTRE WITH SOLAR CYLINDER, SOLAR PUMP ASSEMBLY AND CONTROL UNIT

With its CSZ-2 series, WOLF offers the optimum compact solution – gas condensing technology combined with solar DHW heating – with a solar coverage rate of up to 60 % for buildings of up to 150 m<sup>2</sup> available floor area.

**Gas condensing boiler, solar cylinder, solar pump assembly with SM1-2 solar module and 25 l expansion vessel; 10 l drip pan for solar fluid, standard control unit for gas condensing boiler with BM-2 programming unit incl. outside temperature sensor**

**Solar boiler stop for high solar yield**

**Compact design** – the gas condensing solar centre fits in almost any recess

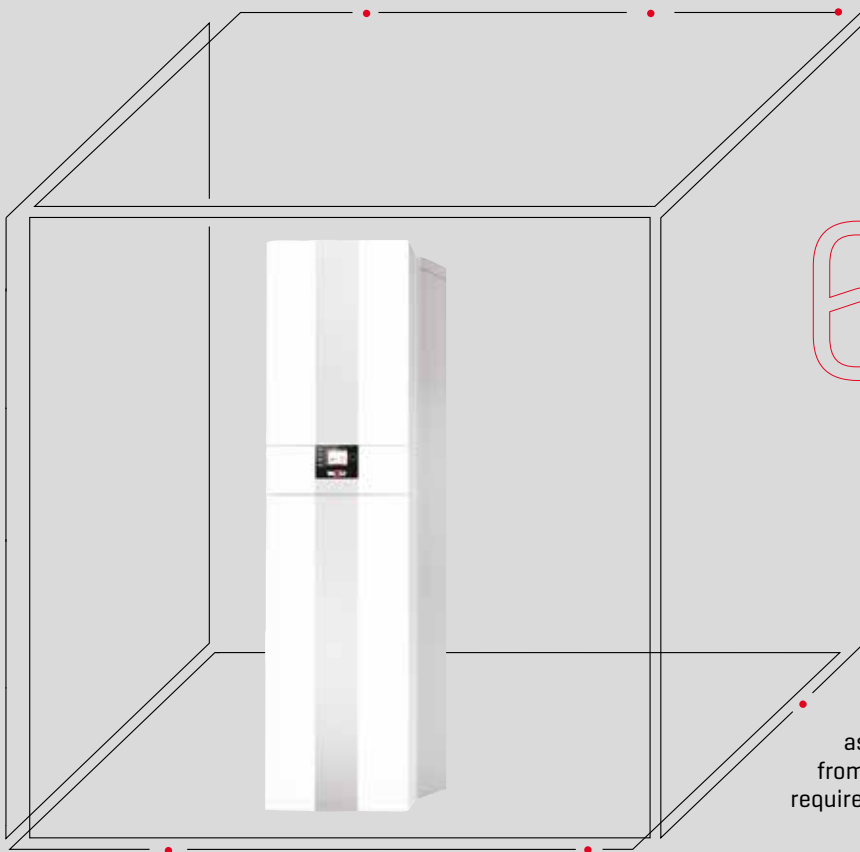

## 6 BENEFITS OF WOLF GAS CONDENSING SOLAR CENTRES

CSZ-2

**Side clearances for service purposes are not required,** as all components are accessible from the front; minimal clearance required on the connection side

**Solar cylinder with highly effective thermal insulation,** incl. cylinder floor insulation

**Connections for central heating and solar circuit** either on the left or right; connections for DHW, cold water and DHW circulation at the top

## CSZ-2-14/300R, -20/300R, -24/300R GAS CONDENSING SOLAR CENTRE WITH SOLAR CYLINDER, SOLAR PUMP ASSEMBLY AND CONTROL UNIT

Gas condensing solar centre, comprising a wall mounted gas condensing boiler with solar cylinder, a solar pump assembly with solar module and 25 l expansion vessel; 10 l drip pan for solar fluid, standard control unit for gas condensing boiler with BM-2 programming unit incl. outside temperature sensor, in a modular design

### MODULATION RANGE for flow / return 50 / 30 °C

### BOOSTER OUTPUT for cylinder heating

CSZ-2-14/300R	from 2.1 to 15.2 kW		
CSZ-2-20/300R	from 4.4 to 20.4 kW	CSZ-2-20/300R	22.2 kW
CSZ-2-24/300R	from 5.6 to 25.8 kW	CSZ-2-24/300R	27.1 kW

**Wall mounted gas condensing boiler**, sealed combustion chamber, for open flue and room sealed operation

High standard seasonal efficiency [to DIN] up to 110 % [net cv] / 99 % [gross cv] for the best possible energy efficiency

Meets the requirements for the "Blue Angel" certificate of environmental excellence according to RAL-UZ 61 when operated with natural gas

Premix burner for natural gas H, LL and LPG, variable modulating heating output from 1.8 kW

With expansion vessel, modulating high efficiency pump [EEI ≤ 0.20] and 3-way valve as standard

Heating water heat exchanger can be pivoted under system pressure for maintenance without having to drain the heating water

WOLF "ALUPro" coated heating water heat exchanger

Convenient access to all components for quick installation and straightforward operation and maintenance

Easy flue gas emissions testing from outside without opening the appliance

Efficient combustion technology with gas-adaptive, self-calibrating combustion controller that adjusts automatically to the prevailing gas quality - flue gas inspection only required every 3 years

Conversion between natural gas and LPG without conversion kit

Automatic CO<sub>2</sub> setting with self-calibrating combustion controller for all gas types [natural gas, LPG]

New WOLF WRS-2 control system can be set and operated via smartphone or PC

Optimum utilisation of condensing technology by controlling the spread without an overflow valve; no return temperature raising required

WOLF Link home LAN/WLAN module allows communication via smartphone, laptop or PC

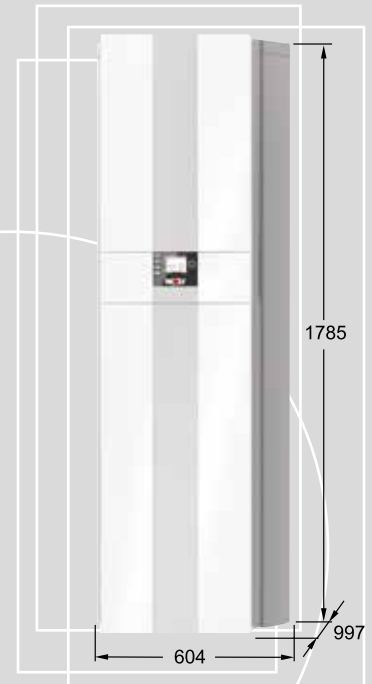

**Solar cylinder**, 285 l capacity, made from steel with two robust, smooth tube internal indirect coils for very hard water, with enamel coating to DIN 4753

Highly effective thermal insulation and low heat losses through high grade rigid PUR foam insulation below the foil jacket of the cylinder

The interior of the cylinder and the indirect coils are protected by an enamel coating and a sacrificial magnesium anode

Large internal indirect coil surface areas ensure a short heat-up time and a high continuous DHW output

Control unit with solar boiler stop for high solar yield

With its compact design in a single casing, requiring just 600 x 1013 mm installation area, the gas condensing solar centre fits in almost any recess

Minimal clearance required on the connection side only

All control and service elements are accessible from the front, enabling a wide range of siting options

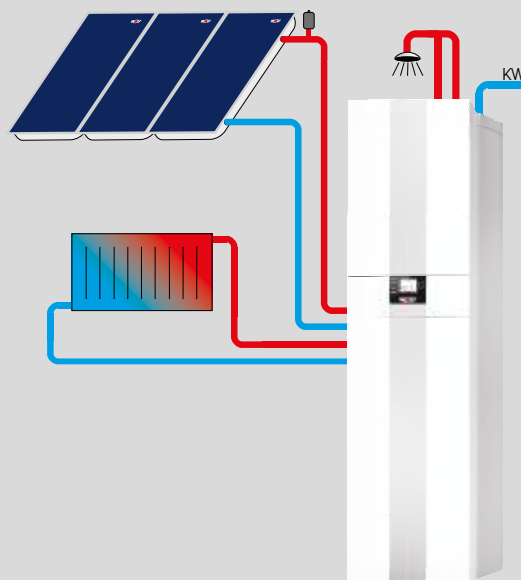

SPECIFICATION	CGB-2 CGB-2K	14	20	24	-	-
		-	-	-	20	24
Energy efficiency class, central heating		A	A	A	A	A
Energy efficiency class, DHW heating					A	A
Rated heating output at 80/60 °C	kW	13.5	18.9/22.2 <sup>1)</sup>	23.8/27.1 <sup>1)</sup>	18.9/22.2 <sup>1)</sup>	23.8/27.1 <sup>1)</sup>
Rated heating output at 50/30 °C	kW	15.2	20.4	25.8	20.4	25.8
Rated heat input	kW	14.0	19.6/23.0	24.6/28.0	19.6/23.0	24.6/28.0
Lowest heating output (modulating) at 80/60 °C	kW	1.8/4.6 <sup>2)</sup>	3.8/6.8 <sup>2)</sup>	4.8/6.8 <sup>2)</sup>	3.8/6.8 <sup>2)</sup>	4.8/6.8 <sup>2)</sup>
Lowest heating output (modulating) at 50/30 °C	kW	2.1/5.4 <sup>2)</sup>	4.4/7.4 <sup>2)</sup>	5.6/7.4 <sup>2)</sup>	4.4/7.4 <sup>2)</sup>	5.6/7.4 <sup>2)</sup>
Lowest heat input (modulating)	kW	1.9/4.9 <sup>2)</sup>	3.9/6.9 <sup>2)</sup>	4.9/6.9 <sup>2)</sup>	3.9/6.9 <sup>2)</sup>	4.9/6.9 <sup>2)</sup>
Heating flow connection	G	¾" (DN 20)	¾" (DN 20)	¾" (DN 20)	¾" (DN 20)	¾" (DN 20)
Heating return connection	G	¾" (DN 20)	¾" (DN 20)	¾" (DN 20)	¾" (DN 20)	¾" (DN 20)
DHW connection	G	¾"	¾"	¾"	¾"	¾"
Cold water connection	G	¾"	¾"	¾"	¾"	¾"
Gas connection	R	½"	½"	½"	½"	½"
Air/flue pipe connection	mm	60/100	60/100	60/100	60/100	60/100
Dimensions						
Depth				378 mm		
Width				440 mm		
Height				790 mm		
Air/flue gas routing	Type	B23 <sub>p</sub> , B33 <sub>p</sub> , C13(x), C33(x), C43(x), C53(x), C63(x), C83(x), C93(x), C <sub>(10)</sub> , C <sub>(11)</sub>				
Gas category		II <sub>2N3B/P</sub>				
Gas connection values						
Natural gas E/H (net cv = 9.5 kWh/m <sup>3</sup> = 34.2 MJ/m <sup>3</sup> )	m <sup>3</sup> /h	1.44	2.06/2.42 <sup>1)</sup>	2.52/2.95 <sup>1)</sup>	2.06/2.42 <sup>1)</sup>	2.52/2.95 <sup>1)</sup>
Natural gas LL (net cv = 8.6 kWh/m <sup>3</sup> = 31.0 MJ/m <sup>3</sup> )	m <sup>3</sup> /h	1.59	2.28/2.67 <sup>1)</sup>	2.79/3.25 <sup>1)</sup>	2.28/2.67 <sup>1)</sup>	2.79/3.25 <sup>1)</sup>
LPG P (net cv = 12.8 kWh/kg = 46.1 MJ/kg)	kg/h	1.07	1.53/1.80 <sup>1)</sup>	1.87/2.19 <sup>1)</sup>	1.53/1.80 <sup>1)</sup>	1.87/2.19 <sup>1)</sup>
Supply pressure, natural gas (permissible min./max.)	mbar	20 [17-25]				
Supply pressure, LPG gas (permissible min./max.)	mbar	30 [25-35]				
Standard seasonal efficiency [to DIN] at 40/30 °C [net cv/gross cv]	%	110/99				
Standard seasonal efficiency [to DIN] at 75/60 °C [net cv/gross cv]	%	107/96				
Efficiency at rated load at 80/60 °C [net cv/gross cv]	%	98/88				
Efficiency at 30 % partial load and TR = 30 °C [net cv/gross cv]	%	108/97				
Flow temperature, factory setting	°C	75				
Flow temperature up to approx.	°C	90				
Max. total pressure	bar	3.0				
Max. residual head for heating circuit: High efficiency pump [EEI ≤ 0.20]						
600 l/h flow rate [14 kW at Δt=20 K]	mbar	550				
860 l/h flow rate [20 kW at Δt=20 K]	mbar	-	430			-
1030 l/h flow rate [24 kW at Δt=20 K]	mbar	-	-	280	-	280
DHW flow rate	l/min	-	-	-	2.0-6.5	2.0-8.0
Minimum flow pressure to EN 625	bar	-	-	-	0.4	0.65
Spec. water throughput D at ΔT = 30 K	l/min	-	-	-	10.3	13.0
Max. permissible total pressure, DHW	bar	-	-	-	10	10
DHW temperature range (adjustable)	°C	-	-	-	45-65	45-65
DHW capacity of heating water heat exchanger	l	1.3				
Expansion vessel, total capacity	l	10				
Expansion vessel, pre-charge pressure	bar	0.75-0.95				
Flue gas temperature 80/60-50/30 at Q <sub>max</sub>	°C	62-45	70-50	76-50	70-50	76-50
Flue gas temperature 80/60-50/30 at Q <sub>min</sub>	°C	30-25	30-25	33-27	30-25	33-27
Flue gas mass flow rate at Q <sub>max</sub>	g/s	6.2	8.8/10.7 <sup>1)</sup>	10.9/13.0 <sup>1)</sup>	8.8/10.7 <sup>1)</sup>	10.9/13.0 <sup>1)</sup>
Flue gas mass flow rate at Q <sub>min</sub>	g/s	0.9	1.8	2.3	1.8	2.3
Available gas fan draught at Q <sub>max</sub>	Pa	125	135	180	135	180
Available gas fan draught at Q <sub>min</sub>	Pa	10	14	17	14	17
Flue gas category		G <sub>52</sub>				
NO <sub>x</sub> class		6				
Amount of condensate at 50/30 °C	l/h	appr. 1.4	appr. 2.0	appr. 2.4	appr. 2.0	appr. 2.4
Condensate pH value		appr. 4.0				
Power consumption on standby	W	3				
Maximum power consumption	W	17-45/59 <sup>1)</sup>	17-51/63 <sup>1)</sup>	17-62/88 <sup>1)</sup>	17-51/63 <sup>1)</sup>	17-62/88 <sup>1)</sup>
IP rating	IP	IP X4D				
Electrical connection/fuse protection		230 V / 50 Hz / 16 A/B				
Total weight	kg	33			35	

<sup>1)</sup> Heating mode/DHW mode  
<sup>2)</sup> Natural gas/LPG (G31)

**DIMENSIONS  
+ CONNECTION DIMENSIONS  
CGB-2/CGB-2K**

**CGB-2/CGB-2K**



**CGB-2**

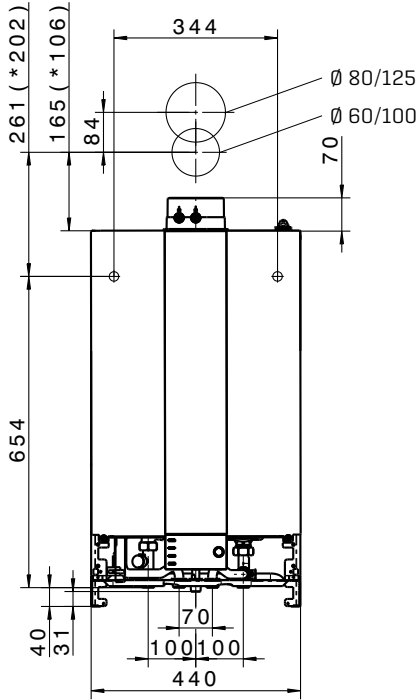

Front view

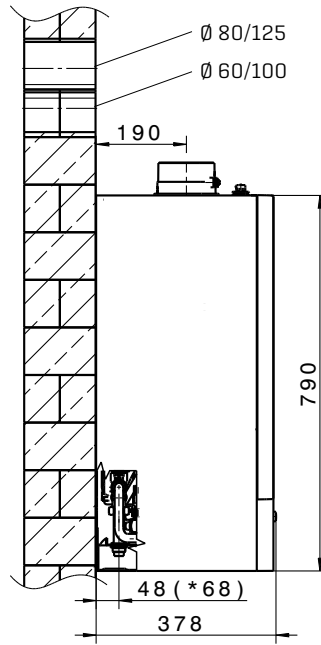

Side view

**CGB-2K**

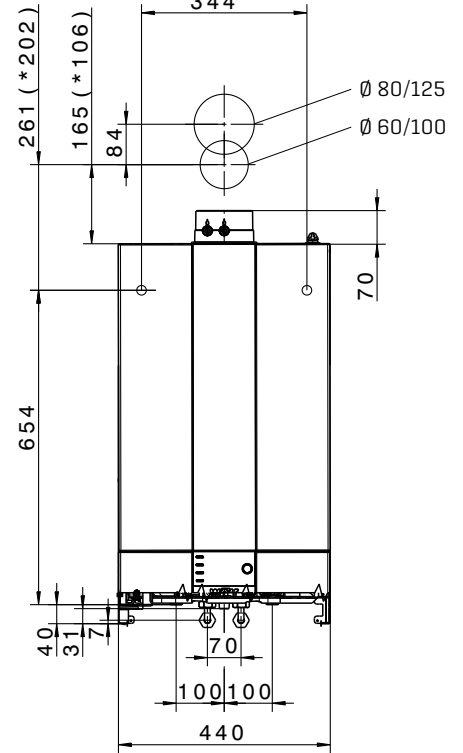

Front view

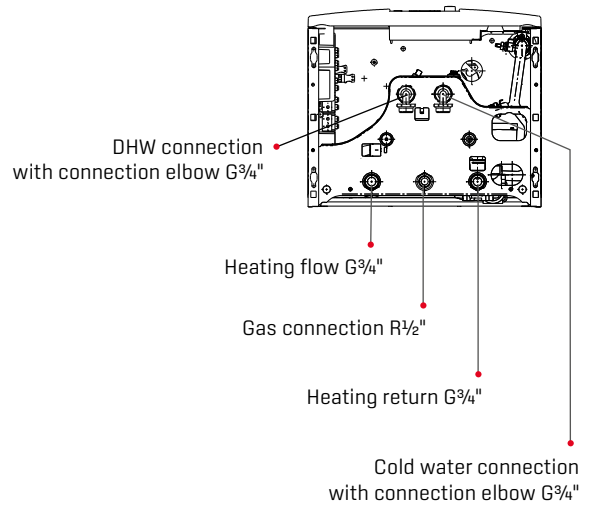
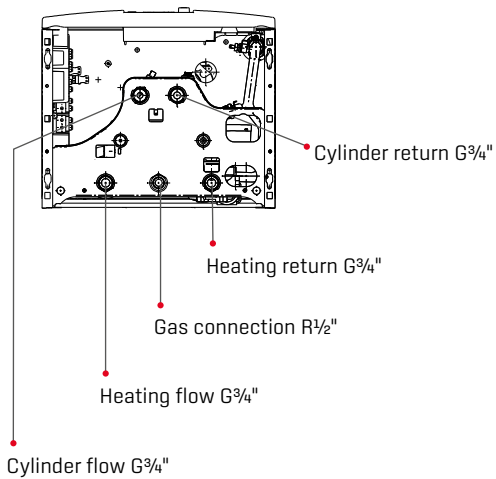

View from below

SPECIFICATION		CGW-2	14/100L	20/120L	24/140L
Energy efficiency class, central heating					
Energy efficiency class, DHW heating					
Rated heating output at 80/60 °C	kW		13.5	18.9/22.2 <sup>1)</sup>	23.8/27.1 <sup>1)</sup>
Rated heating output at 50/30 °C	kW		15.2	20.4	25.8
Rated heat input	kW		14.0	19.6/23.0	24.6/28.0
Lowest heating output (modulating) at 80/60 °C	kW		1.8/4.6 <sup>2)</sup>	3.8/6.8 <sup>2)</sup>	4.8/6.8 <sup>2)</sup>
Lowest heating output (modulating) at 50/30 °C	kW		2.1/5.4 <sup>2)</sup>	4.4/7.4 <sup>2)</sup>	5.6/7.4 <sup>2)</sup>
Lowest heat input (modulating)	kW		1.9/4.9 <sup>2)</sup>	3.9/6.9 <sup>2)</sup>	4.9/6.9 <sup>2)</sup>
Heating flow connection	G		¾" (DN 20)	¾" (DN 20)	¾" (DN 20)
Heating return connection	G		¾" (DN 20)	¾" (DN 20)	¾" (DN 20)
DHW connection	G		½"	½"	½"
Cold water connection / DHW circulation	G		¾"	¾"	¾"
Gas connection	R		½"	½"	½"
Air/flue pipe connection	mm		60/100	60/100	60/100
Dimensions					
Depth			378 mm		
Width			800 mm		
Height			790 mm		
Air/flue gas routing	Type		B23 <sub>p</sub> , B33 <sub>p</sub> , C13(x), C33(x), C43(x), C53(x), C63(x), C83(x), C93(x), C <sub>(10)</sub> , C <sub>(11)</sub>		
Gas category			II <sub>2N3B/P</sub>		
Gas connection values					
Natural gas E/H [net cv = 9.5 kWh/m <sup>3</sup> = 34.2 MJ/m <sup>3</sup> ]	m <sup>3</sup> /h		1.44	2.06/2.42 <sup>1)</sup>	2.52/2.95 <sup>1)</sup>
Natural gas LL [net cv = 8.6 kWh/m <sup>3</sup> = 31.0 MJ/m <sup>3</sup> ]	m <sup>3</sup> /h		1.59	2.28/2.67 <sup>1)</sup>	2.79/3.25 <sup>1)</sup>
LPG P [net cv = 12.8 kWh/kg = 46.1 MJ/kg]	kg/h		1.07	1.53/1.80 <sup>1)</sup>	1.87/2.19 <sup>1)</sup>
Supply pressure, natural gas [permissible min./max.]	mbar		20 [17-25]		
Supply pressure, LPG gas [permissible min./max.]	mbar		30 [25-35]		
Standard seasonal efficiency [to DIN] at 40/30 °C [net cv/gross cv]	%		110/99		
Standard seasonal efficiency [to DIN] at 75/60 °C [net cv/gross cv]	%		107/96		
Efficiency at rated load at 80/60 °C [net cv/gross cv]	%		98/88		
Efficiency at 30 % partial load and TR = 30 °C [net cv/gross cv]	%		108/97		
Flow temperature, factory setting	°C		75		
Flow temperature up to approx.	°C		90		
Max. total pressure	bar		3.0		
Max. residual head for heating circuit: High efficiency pump [EEI ≤ 0.20]					
600 l/h flow rate [14 kW at Δt=20 K]	mbar		550		
860 l/h flow rate [20 kW at Δt=20 K]	mbar		-	430	-
1030 l/h flow rate [24 kW at Δt=20 K]	mbar		-	-	280
Max. permissible total pressure, DHW	bar		10		
DHW temperature range [adjustable]	°C		15-65		
Water capacity of heating water heat exchanger	l		1.3		
Nominal capacity of stratification cylinder / equivalent nominal capacity	l		44 / 100	44 / 120	44 / 140
Spec. water throughput D at ΔT = 30 K	l/min		14.3	18.0	20
Continuous DHW output	l/h [kW]		366 [14.6]	560 [23.1]	684 [27.8]
Output factor to DIN 4708	N <sub>L</sub>		0.8	1.1	1.5
DHW output	l/10 min		115	150	171
Standby heat loss to EN 12897	kWh/24 h		0.8		
Corrosion protection, DHW heat exchanger / cylinder			Stainless steel		
Expansion vessel, total capacity	l		10		
Expansion vessel, pre-charge pressure	bar		0.75-0.95		
Flue gas temperature 80/60-50/30 at Q <sub>max</sub>	°C		62-45	70-50	76-50
Flue gas temperature 80/60-50/30 at Q <sub>min</sub>	°C		30-25	30-25	33-27
Flue gas mass flow rate at Q <sub>max</sub>	g/s		6.2	8.8/10.7 <sup>1)</sup>	10.9/13.0 <sup>1)</sup>
Flue gas mass flow rate at Q <sub>min</sub>	g/s		0.9	1.8	2.3
Available gas fan draught at Q <sub>max</sub>	Pa		125	135	180
Available gas fan draught at Q <sub>min</sub>	Pa		10	14	17
Flue gas category			G <sub>52</sub>		
NO <sub>x</sub> class			5		
Amount of condensate at 50/30 °C	l/h		appr. 1.4	appr. 2.0	appr. 2.4
Condensate pH value			appr. 4.0		
Power consumption on standby	W		3		
Maximum power consumption	W		17-45/93 <sup>1)</sup>	17-51/110 <sup>1)</sup>	17-62/135 <sup>1)</sup>
IP rating	IP		IP X4D		
Electrical connection/fuse protection			230 V / 50 Hz / 16 A/B		
Total weight	kg		54 [35+19]		

<sup>1)</sup> Heating mode/DHW mode

<sup>2)</sup> Natural gas/LPG [G31]

**DIMENSIONS**  
**+ CONNECTION DIMENSIONS**  
**CGW-2**

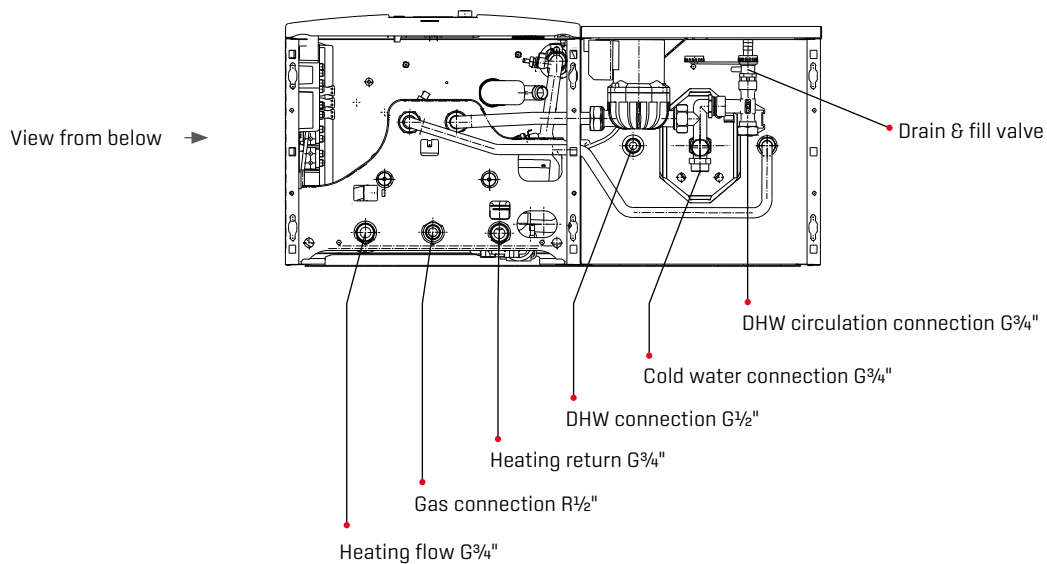
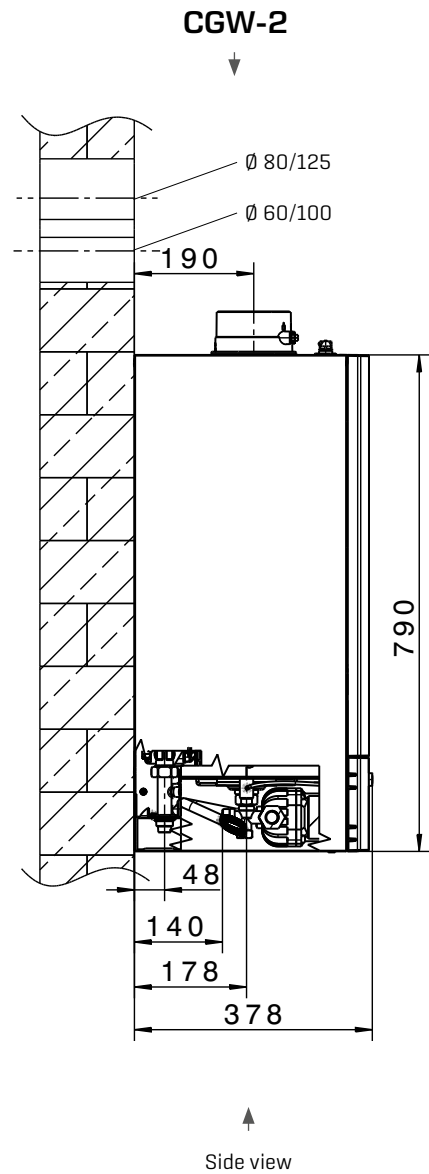
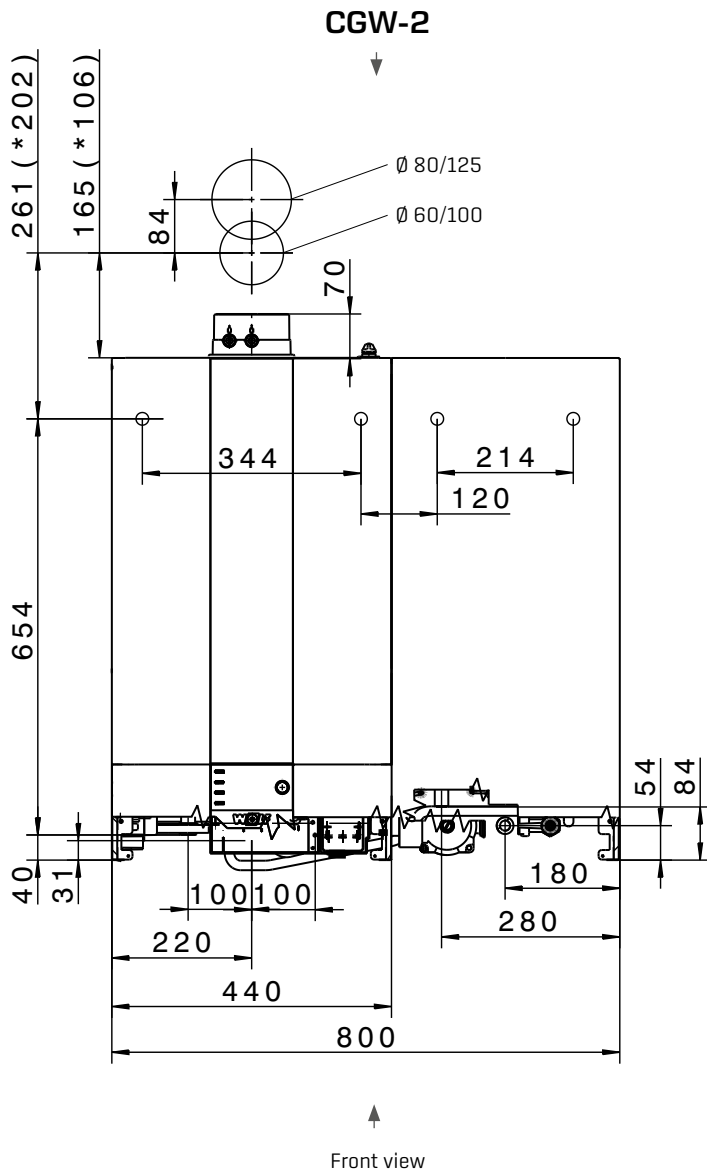

SPECIFICATION	CGS-2	14/120L	20/160L	24/200L
Energy efficiency class, central heating				
Energy efficiency class, DHW heating				
Rated heating output at 80/60 °C	kW	13.5	18.9/22.2 <sup>1)</sup>	23.8/27.1 <sup>1)</sup>
Rated heating output at 50/30 °C	kW	15.2	20.4	25.8
Rated heat input	kW	14.0	19.6/23.0	24.6/28.0
Lowest heating output (modulating) at 80/60 °C	kW	1.8/4.6 <sup>2)</sup>	3.8/6.8 <sup>2)</sup>	4.8/6.8 <sup>2)</sup>
Lowest heating output (modulating) at 50/30 °C	kW	2.1/5.4 <sup>2)</sup>	4.4/7.4 <sup>2)</sup>	5.6/7.4 <sup>2)</sup>
Lowest heat input (modulating)	kW	1.9/4.9 <sup>2)</sup>	3.9/6.9 <sup>2)</sup>	4.9/6.9 <sup>2)</sup>
Heating flow connection	G	¾" (DN 20)	¾" (DN 20)	¾" (DN 20)
Heating return connection	G	¾" (DN 20)	¾" (DN 20)	¾" (DN 20)
DHW connection	G	½"	½"	½"
Cold water connection / DHW circulation	G	¾"	¾"	¾"
Gas connection	R	½"	½"	½"
Air/flue pipe connection	mm	60/100	60/100	60/100
Dimensions				
Depth		_____	378 mm	_____
Width		_____	600 mm	_____
Height		_____	1462 mm	_____
Air/flue gas routing	Type	B23 <sub>p</sub> , B33 <sub>p</sub> , C13(x), C33(x), C43(x), C53(x), C63(x), C83(x), C93(x), C <sub>(10)</sub> , C <sub>(11)</sub>		
Gas category		II <sub>2N3B/P</sub>		
Gas connection values				
Natural gas E/H [net cv = 9.5 kWh/m <sup>3</sup> = 34.2 MJ/m <sup>3</sup> ]	m <sup>3</sup> /h	1.44	2.06/2.42 <sup>1)</sup>	2.52/2.95 <sup>1)</sup>
Natural gas LL [net cv = 8.6 kWh/m <sup>3</sup> = 31.0 MJ/m <sup>3</sup> ]	m <sup>3</sup> /h	1.59	2.28/2.67 <sup>1)</sup>	2.79/3.25 <sup>1)</sup>
LPG P [net cv = 12.8 kWh/kg = 46.1 MJ/kg]	kg/h	1.07	1.53/1.80 <sup>1)</sup>	1.87/2.19 <sup>1)</sup>
Supply pressure, natural gas [permissible min./max.]	mbar	20 [17-25]		
Supply pressure, LPG gas [permissible min./max.]	mbar	30 [25-35]		
Standard seasonal efficiency [to DIN] at 40/30 °C [net cv/gross cv]	%	110/99		
Standard seasonal efficiency [to DIN] at 75/60 °C [net cv/gross cv]	%	107/96		
Efficiency at rated load at 80/60 °C [net cv/gross cv]	%	98/88		
Efficiency at 30 % partial load and TR = 30 °C [net cv/gross cv]	%	108/97		
Flow temperature, factory setting	°C	75		
Flow temperature up to approx.	°C	90		
Max. total pressure	bar	3.0		
Max. residual head for heating circuit: High efficiency pump [EEI ≤ 0.20]				
600 l/h flow rate [14 kW at Δt=20 K]	mbar	550		
860 l/h flow rate [20 kW at Δt=20 K]	mbar	-	430	_____
1030 l/h flow rate [24 kW at Δt=20 K]	mbar	-	-	280
Max. permissible total pressure, DHW	bar	10		
DHW temperature range [adjustable]	°C	15-65		
Water capacity of heating water heat exchanger	l	1.3		
Nominal capacity of stratification cylinder / equivalent nominal capacity	l	90 / 120	90 / 160	90 / 200
Spec. water throughput D at ΔT = 30 K	l/min	18.7	23.2	25.2
Continuous DHW output	l/h [kW]	366 [14.6]	560 [23.1]	684 [27.8]
Output factor to DIN 4708	N <sub>L</sub>	1.3	2.1	2.5
DHW output	l/10 min	161	199	215
Standby heat loss to EN 12897	kWh/24 h	1.0		
Corrosion protection, DHW heat exchanger / cylinder		Stainless steel / two-layer enamel coating to DIN 4753		
Expansion vessel, total capacity	l	10		
Expansion vessel, pre-charge pressure	bar	0.75-0.95		
Flue gas temperature 80/60-50/30 at Q <sub>max</sub>	°C	62-45	70-50	76-50
Flue gas temperature 80/60-50/30 at Q <sub>min</sub>	°C	30-25	30-25	33-27
Flue gas mass flow rate at Q <sub>max</sub>	g/s	6.2	8.8/10.7 <sup>1)</sup>	10.9/13.0 <sup>1)</sup>
Flue gas mass flow rate at Q <sub>min</sub>	g/s	0.9	1.8	2.3
Available gas fan draught at Q <sub>max</sub>	Pa	125	135	180
Available gas fan draught at Q <sub>min</sub>	Pa	10	14	17
Flue gas category		G <sub>52</sub>		
NO <sub>x</sub> class		5		
Amount of condensate at 50/30 °C	l/h	appr. 1.4	appr. 2.0	appr. 2.4
Condensate pH value		appr. 4.0		
Power consumption on standby	W	3		
Maximum power consumption	W	17-45/93 <sup>1)</sup>	17-51/110 <sup>1)</sup>	17-62/135 <sup>1)</sup>
IP rating	IP	IP X4D		
Electrical connection/fuse protection		230 V / 50 Hz / 16 A/B		
Total weight	kg	84 [35+49]		

<sup>1)</sup> Heating mode/DHW mode

<sup>2)</sup> Natural gas/LPG [G31]



**DIMENSIONS  
+ CONNECTION DIMENSIONS  
CGS-2L**

**CGS-2L**

**CGS-2L**

**CGS-2L**

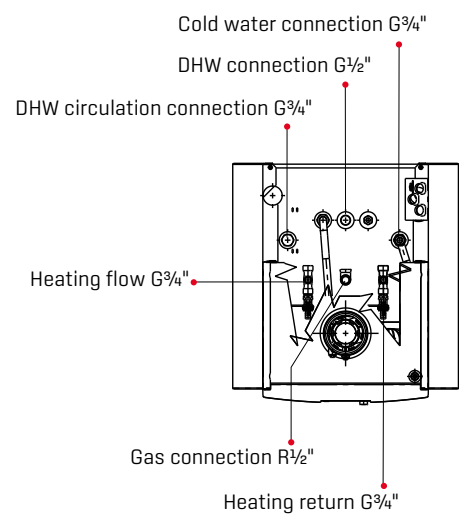
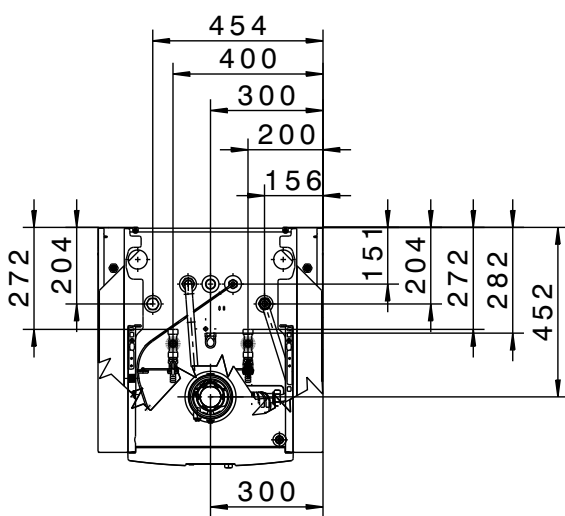
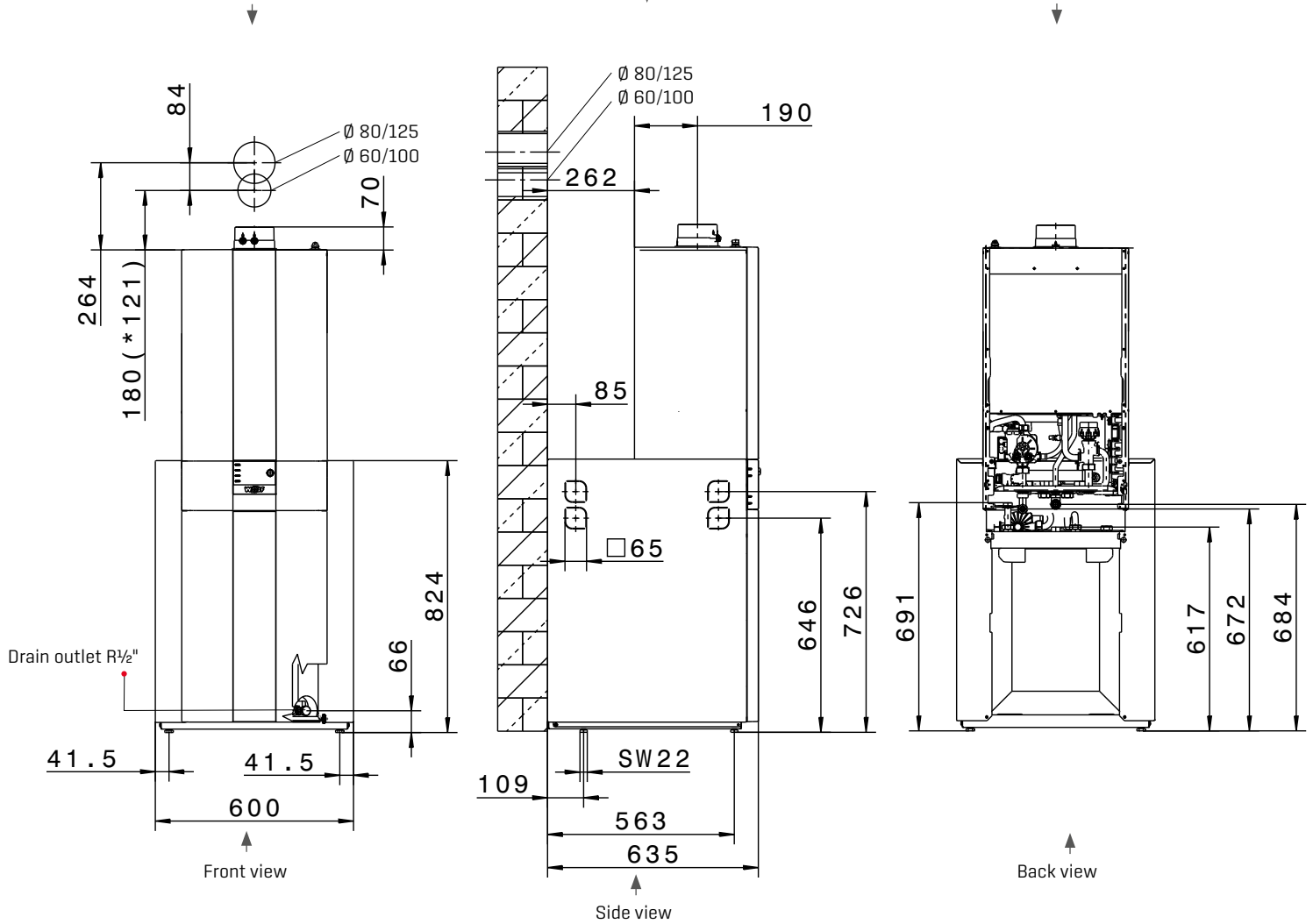

Top view

SPECIFICATION		CGS-2	14/150R	20/150R	24/150R
Energy efficiency class, central heating					
Energy efficiency class, DHW heating					
Rated heating output at 80/60 °C	kW		13.5	18.9/22.2 <sup>1)</sup>	23.8/27.1 <sup>1)</sup>
Rated heating output at 50/30 °C	kW		15.2	20.4	25.8
Rated heat input	kW		14.0	19.6/23.0	24.6/28.0
Lowest heating output (modulating) at 80/60 °C	kW		1.8/4.6 <sup>2)</sup>	3.8/6.8 <sup>2)</sup>	4.8/6.8 <sup>2)</sup>
Lowest heating output (modulating) at 50/30 °C	kW		2.1/5.4 <sup>2)</sup>	4.4/7.4 <sup>2)</sup>	5.6/7.4 <sup>2)</sup>
Lowest heat input (modulating)	kW		1.9/4.9 <sup>2)</sup>	3.9/6.9 <sup>2)</sup>	4.9/6.9 <sup>2)</sup>
Heating flow connection	G		¾" (DN 20)	¾" (DN 20)	¾" (DN 20)
Heating return connection	G		¾" (DN 20)	¾" (DN 20)	¾" (DN 20)
DHW connection	G		½"	½"	½"
Cold water connection / DHW circulation	G		¾"	¾"	¾"
Gas connection	R		½"	½"	½"
Air/flue pipe connection	mm		60/100	60/100	60/100
Dimensions					
Depth			635 mm		
Width			600 mm		
Height			1792 mm		
Air/flue gas routing	Type		B23 <sub>p</sub> , B33 <sub>p</sub> , C13(x), C33(x), C43(x), C53(x), C63(x), C83(x), C93(x), C <sub>(10)</sub> , C <sub>(11)</sub>		
Gas category			II <sub>2N3B/P</sub>		
Gas connection values					
Natural gas E/H [net cv = 9.5 kWh/m <sup>3</sup> = 34.2 MJ/m <sup>3</sup> ]	m <sup>3</sup> /h		1.44	2.06/2.42 <sup>1)</sup>	2.52/2.95 <sup>1)</sup>
Natural gas LL [net cv = 8.6 kWh/m <sup>3</sup> = 31.0 MJ/m <sup>3</sup> ]	m <sup>3</sup> /h		1.59	2.28/2.67 <sup>1)</sup>	2.79/3.25 <sup>1)</sup>
LPG P [net cv = 12.8 kWh/kg = 46.1 MJ/kg]	kg/h		1.07	1.53/1.80 <sup>1)</sup>	1.87/2.19 <sup>1)</sup>
Supply pressure, natural gas [permissible min./max.]	mbar		20 [17-25]		
Supply pressure, LPG gas [permissible min./max.]	mbar		30 [25-35]		
Standard seasonal efficiency [to DIN] at 40/30 °C [net cv/gross cv]	%		110/99		
Standard seasonal efficiency [to DIN] at 75/60 °C [net cv/gross cv]	%		107/96		
Efficiency at rated load at 80/60 °C [net cv/gross cv]	%		98/88		
Efficiency at 30 % partial load and TR = 30 °C [net cv/gross cv]	%		108/97		
Flow temperature, factory setting	°C		75		
Flow temperature up to approx.	°C		90		
Max. total pressure	bar		3.0		
Max. residual head for heating circuit: High efficiency pump [EEI ≤ 0.20]					
600 l/h flow rate [14 kW at Δt=20 K]	mbar		550		
860 l/h flow rate [20 kW at Δt=20 K]	mbar		-	430	-
1030 l/h flow rate [24 kW at Δt=20 K]	mbar		-	-	280
Max. permissible total pressure, DHW	bar		10		
DHW temperature range [adjustable]	°C		15-65		
Water capacity of heating water heat exchanger	l		1.3		
Nominal capacity of cylinder with internal indirect coil	l		145		
Spec. water throughput D at ΔT = 30 K	l/min		19.7	21.4	21.7
Continuous DHW output	l/h [kW]		324 [13.6]	555 [22.6]	612 [25]
Output factor to DIN 4708	N <sub>L</sub>		1.7	2.0	2.2
DHW output	l/10 min		162	176	182
Standby heat loss to EN 12897	kWh/24 h		1.47		
Corrosion protection, DHW heat exchanger / cylinder			Stainless steel / two-layer enamel coating to DIN 4753		
Expansion vessel, total capacity	l		10		
Expansion vessel, pre-charge pressure	bar		0.75-0.95		
Flue gas temperature 80/60-50/30 at Q <sub>max</sub>	°C		62-45	70-50	76-50
Flue gas temperature 80/60-50/30 at Q <sub>min</sub>	°C		30-25		33-27
Flue gas mass flow rate at Q <sub>max</sub>	g/s		6.2	8.8/10.7 <sup>1)</sup>	10.9/13.0 <sup>1)</sup>
Flue gas mass flow rate at Q <sub>min</sub>	g/s		0.9	1.8	2.3
Available gas fan draught at Q <sub>max</sub>	Pa		125	135	180
Available gas fan draught at Q <sub>min</sub>	Pa		10	14	17
Flue gas category			G <sub>52</sub>		
NO <sub>x</sub> class			5		
Amount of condensate at 50/30 °C	l/h		appr. 1.4	appr. 2.0	appr. 2.4
Condensate pH value			appr. 4.0		
Power consumption on standby	W		3		
Maximum power consumption	W		17-49/59 <sup>1)</sup>	17-51/63 <sup>1)</sup>	17-62/88 <sup>1)</sup>
IP rating	IP		IP X4D		
Electrical connection/fuse protection			230 V / 50 Hz / 16 A/B		
Total weight	kg		115 [35+80]		

<sup>1)</sup> Heating mode/DHW mode

<sup>2)</sup> Natural gas/LPG [G31]

**DIMENSIONS  
+ CONNECTION DIMENSIONS  
CGS-2R**

**CGS-2R**

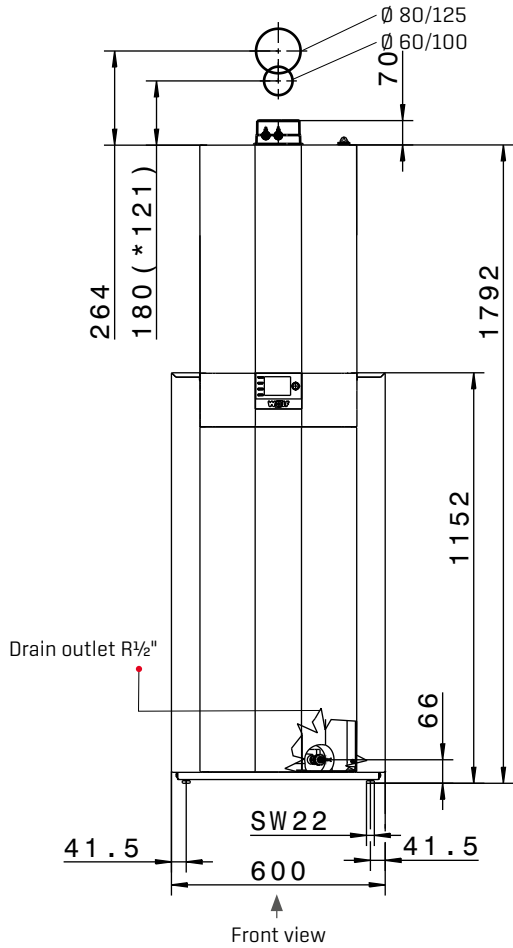

Front view

**CGS-2R**

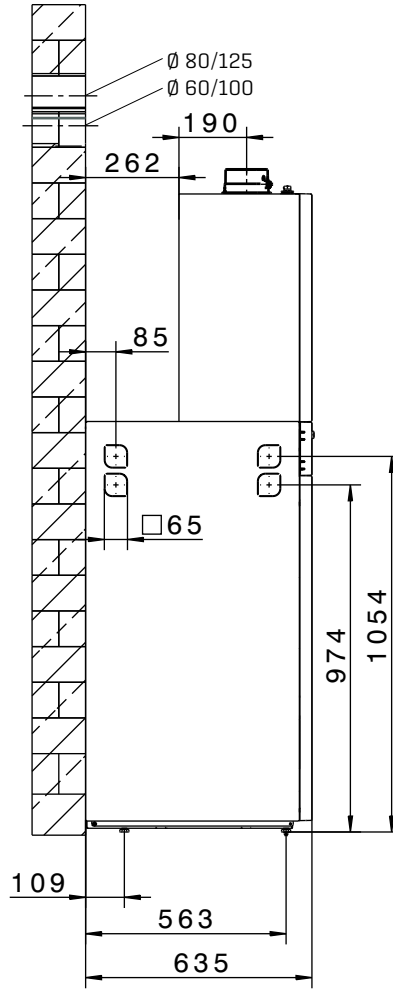

Side view

**CGS-2R**

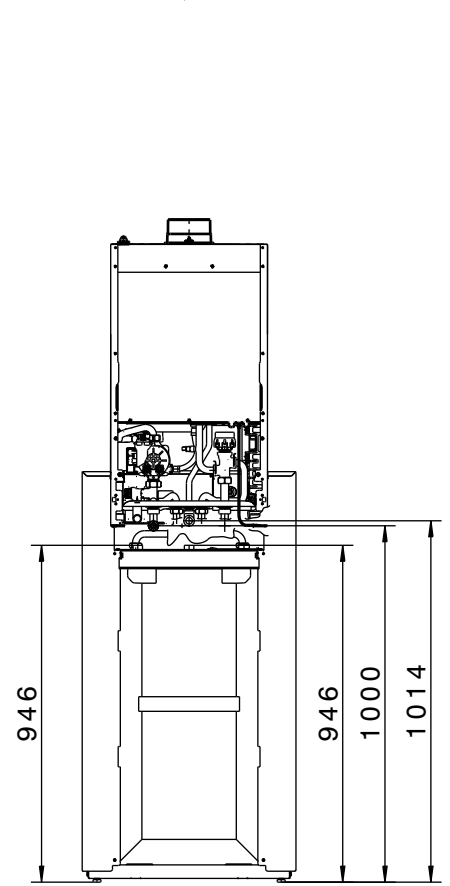

Back view

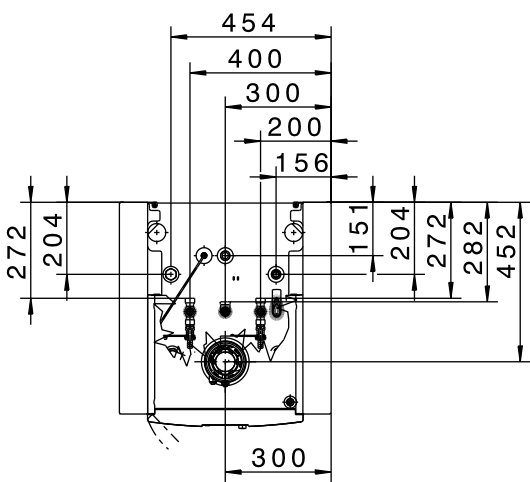

Top view

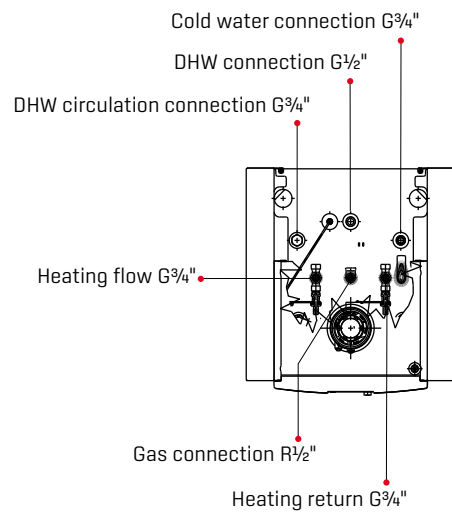

SPECIFICATION		CSZ-2	14/300R	20/300R	24/300R
Energy efficiency class, central heating					
Energy efficiency class, DHW heating					
Rated heating output at 80/60 °C	kW		13.5	18.9/22.2 <sup>1)</sup>	23.8/27.1 <sup>1)</sup>
Rated heating output at 50/30 °C	kW		15.2	20.4	25.8
Rated heat input	kW		14.0	19.6/23.0	24.6/28.0
Lowest heating output (modulating) at 80/60 °C	kW		1.8/4.6 <sup>2)</sup>	3.8/6.8 <sup>2)</sup>	4.8/6.8 <sup>2)</sup>
Lowest heating output (modulating) at 50/30 °C	kW		2.1/5.4 <sup>2)</sup>	4.4/7.4 <sup>2)</sup>	5.6/7.4 <sup>2)</sup>
Lowest heat input (modulating)	kW		1.9/4.9 <sup>2)</sup>	3.9/6.9 <sup>2)</sup>	4.9/6.9 <sup>2)</sup>
Heating flow connection	G		¾" (DN 20)	¾" (DN 20)	¾" (DN 20)
Heating return connection	G		¾" (DN 20)	¾" (DN 20)	¾" (DN 20)
DHW connection	G		½"	½"	½"
Cold water connection / DHW circulation	G		¾"	¾"	¾"
Gas connection	R		½"	½"	½"
Air/flue pipe connection	mm		60/100	60/100	60/100
Dimensions					
Depth			1013 mm		
Width			600 mm		
Height			1785 mm		
Air/flue gas routing	Type		B23 <sub>p</sub> , B33 <sub>p</sub> , C13(x), C33(x), C43(x), C53(x), C63(x), C83(x), C93(x), C <sub>(10)</sub> , C <sub>(11)</sub>		
Gas category			II <sub>2N3B/P</sub>		
Gas connection values					
Natural gas E/H [net cv = 9.5 kWh/m <sup>3</sup> = 34.2 MJ/m <sup>3</sup> ]	m <sup>3</sup> /h		1.44	2.06/2.42 <sup>1)</sup>	2.52/2.95 <sup>1)</sup>
Natural gas LL [net cv = 8.6 kWh/m <sup>3</sup> = 31.0 MJ/m <sup>3</sup> ]	m <sup>3</sup> /h		1.59	2.28/2.67 <sup>1)</sup>	2.79/3.25 <sup>1)</sup>
LPG P [net cv = 12.8 kWh/kg = 46.1 MJ/kg]	kg/h		1.07	1.53/1.80 <sup>1)</sup>	1.87/2.19 <sup>1)</sup>
Supply pressure, natural gas [permissible min./max.]	mbar		20 [17-25]		
Supply pressure, LPG gas [permissible min./max.]	mbar		30 [25-35]		
Standard seasonal efficiency [to DIN] at 40/30 °C [net cv/gross cv]	%		110/99		
Standard seasonal efficiency [to DIN] at 75/60 °C [net cv/gross cv]	%		107/96		
Efficiency at rated load at 80/60 °C [net cv/gross cv]	%		98/88		
Efficiency at 30 % partial load and TR = 30 °C [net cv/gross cv]	%		108/97		
Flow temperature, factory setting	°C		75		
Flow temperature up to approx.	°C		90		
Max. total pressure	bar		3.0		
Max. residual head for heating circuit: High efficiency pump [EEI ≤ 0.20]					
600 l/h flow rate [14 kW at Δt=20 K]	mbar		550		
860 l/h flow rate [20 kW at Δt=20 K]	mbar		-	430	-
1030 l/h flow rate [24 kW at Δt=20 K]	mbar		-	-	280
Max. permissible total pressure, DHW	bar		10		
DHW temperature range [adjustable]	°C		15-65		
Water capacity of the heat exchanger, heating/solar	l		6.6 / 8.8		
Nominal cylinder capacity	l		285		
Spec. water throughput D at ΔT = 30 K	l/min		20.5	24.5	24.5
Continuous DHW output	l/h [kW]		366 [14.6]	560 [23.1]	684 [27.8]
Output factor to DIN 4708	N <sub>L</sub>		1.5	2.3	2.3
DHW output	l/10 min		175	210	210
Standby heat loss to EN 12897	kWh/24 h		2.3		
Cylinder corrosion protection			Two-layer enamel coating to DIN 4753		
Expansion vessel, total capacity	l		10		
Expansion vessel, pre-charge pressure	bar		0.75-0.95		
Flue gas temperature 80/60-50/30 at Q <sub>max</sub>	°C		62-45	70-50	76-50
Flue gas temperature 80/60-50/30 at Q <sub>min</sub>	°C		30-25		33-27
Flue gas mass flow rate at Q <sub>max</sub>	g/s		6.2	8.8/10.7 <sup>1)</sup>	10.9/13.0 <sup>1)</sup>
Flue gas mass flow rate at Q <sub>min</sub>	g/s		0.9	1.8	2.3
Available gas fan draught at Q <sub>max</sub>	Pa		125	135	180
Available gas fan draught at Q <sub>min</sub>	Pa		10	14	17
Flue gas category			G <sub>52</sub>		
NO <sub>x</sub> class			5		
Amount of condensate at 50/30 °C	l/h		appr. 1.4	appr. 2.0	appr. 2.4
Condensate pH value			appr. 4.0		
Power consumption on standby	W		3		
Maximum power consumption	W		17-49/59 <sup>1)</sup>	17-51/63 <sup>1)</sup>	17-62/88 <sup>1)</sup>
IP rating	IP		IP X4D		
Electrical connection/fuse protection			230 V / 50 Hz / 16 A/B		
Total weight	kg		160 [35+125]		

<sup>1)</sup> Heating mode/DHW mode

<sup>2)</sup> Natural gas/LPG [G31]

**DIMENSIONS**  
 + CONNECTION DIMENSIONS  
**CSZ-2R**

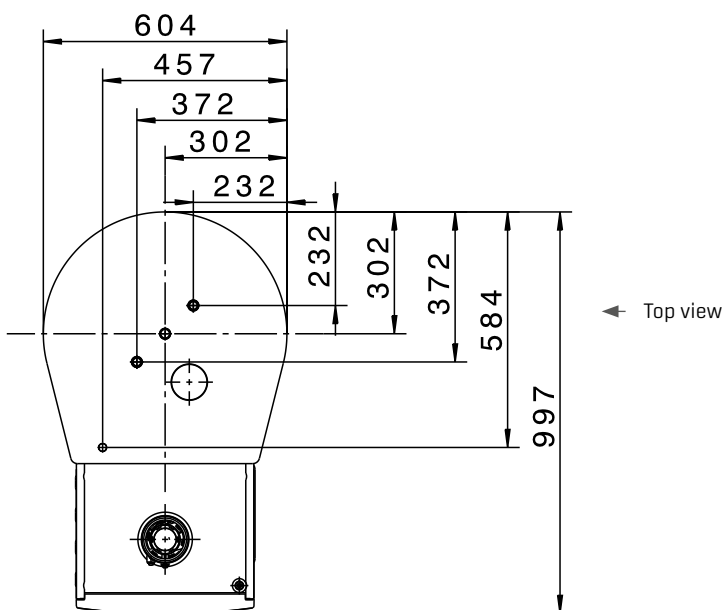
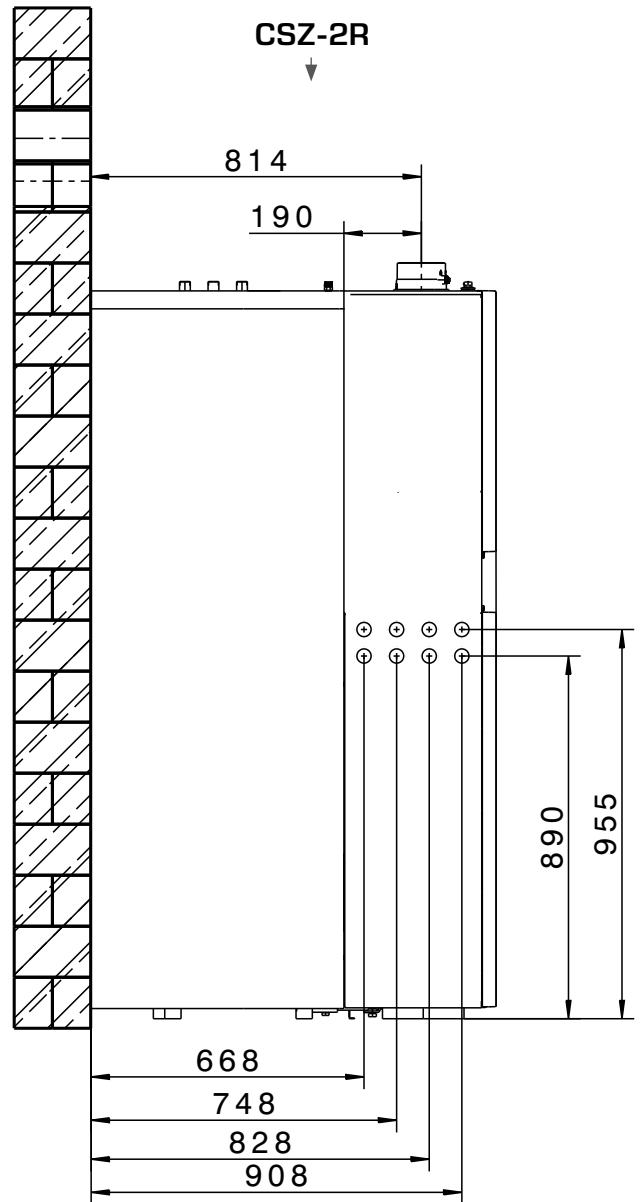
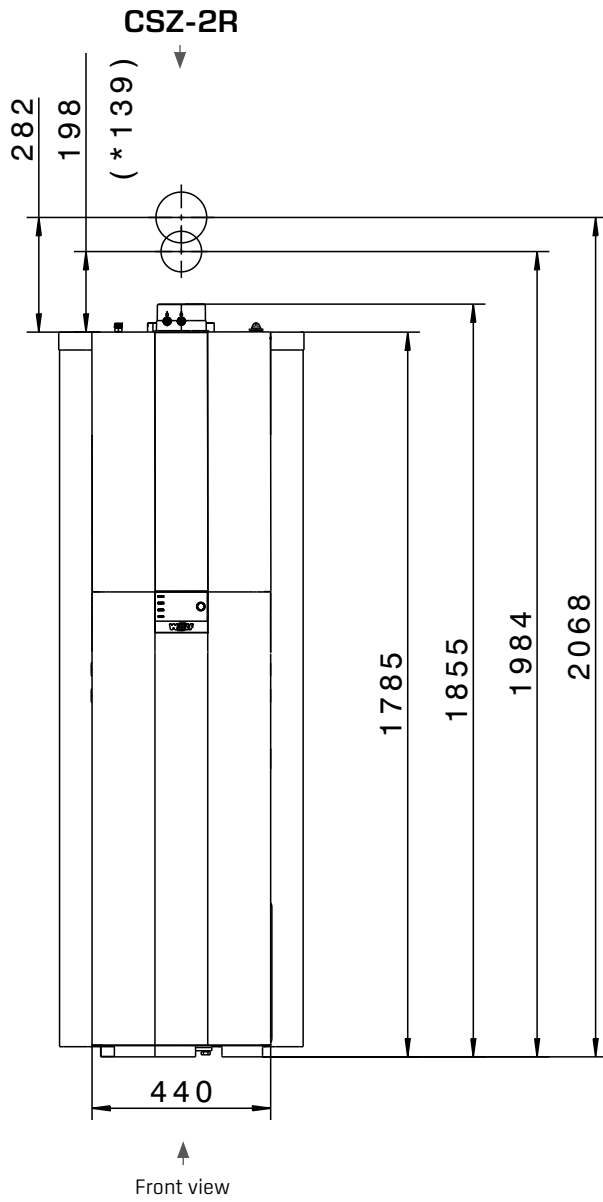

SPECIFICATION	CSW	120
Cylinder energy efficiency class		<b>B</b>
Cylinder capacity	l	115
Continuous cylinder output {80/60 - 10/45 °C}	kW - l/h	29 - 710
Standby heat loss	kWh/24 h	1.11
Output factor	N <sub>l</sub>	1.0
Permissible operating pressure, DHW	bar	10
Permissible operating pressure, heating water	bar	12
Max. permissible cylinder water temperature	°C	95
Max. permissible heating water temperature	°C	110
Cold water connection	G	¾"
DHW connection	G	¾"
Cylinder flow	R	¾"
Cylinder return	R	¾"
DHW circulation	G	¾"
Drain outlet	R	½"
Sensor well	∅ mm	12
Dry weight	kg	65

**DIMENSIONS**  
**+ CONNECTION DIMENSIONS**  
**CSW-120**

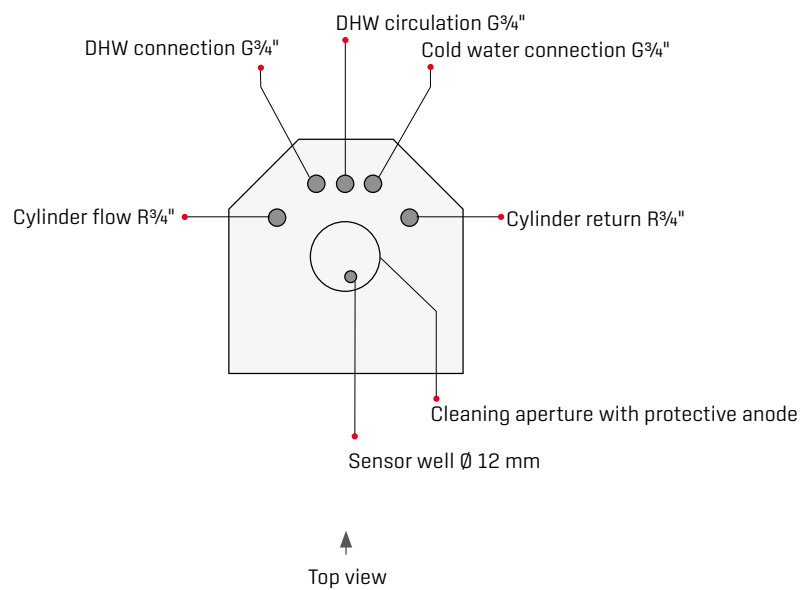
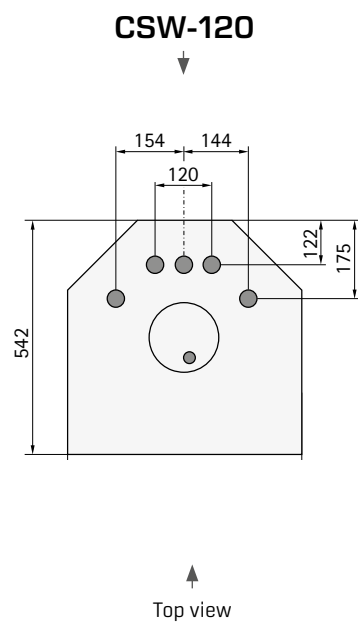
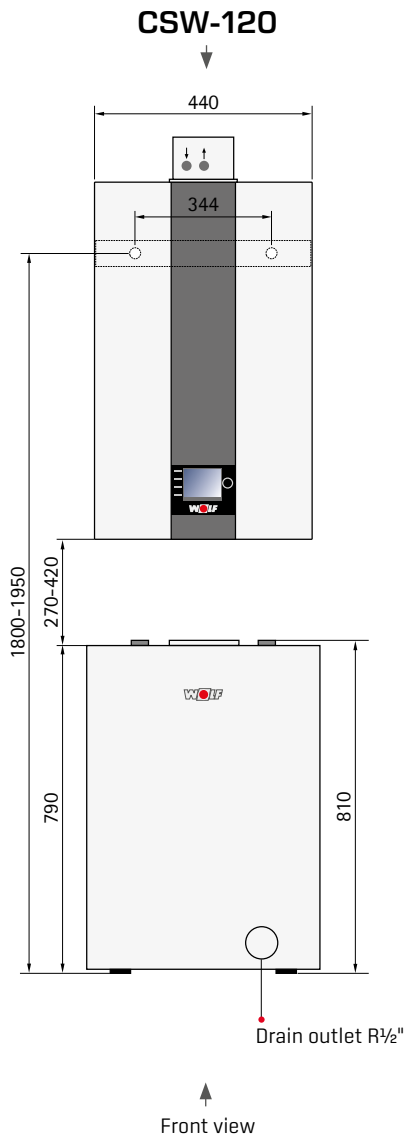

# STANDARD CONTROL UNIT

The operation of a CGB-2[K]/CGW-2/CGS-2/CSZ-2 gas condensing boiler requires either an AM display module or a BM-2 programming unit.

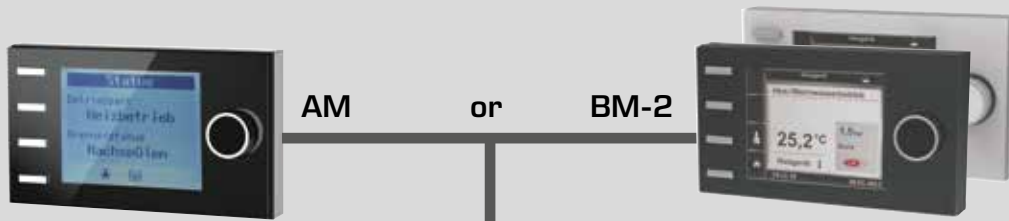

The AM functions solely as a display module for the heat generator. Appliance-specific parameters and values can be programmed and displayed.

### AM display module

- Display module for the heat generator
- Only required if BM-2 is used as a remote control or in a cascade circuit
- Operated by rotary selector with pushbutton function
- 4 quick start keys for frequently used functions
- Backlit LCD
- AM is always inside the heat generator

### BM-2 programming unit

- in black and white
- weather-compensated flow temperature
- Time programs for heating, DHW and DHW circulation
- 3.5" colour display
- Easy user prompts via plain text display
- Operated by rotary selector with pushbutton function
- 4 function keys for frequently used functions
- microSD card slot for software update
- Installation either inside the boiler control unit or in wall mounting base as a remote control
- Only one programming unit required for multi boiler systems
- Can be extended with MM-2 mixer module (up to 7 heating circuits with mixer)
- Part of the standard delivery for CSZ-2
- BM-2 can also be used as a remote control for the CWL Excellent ventilation unit (one programming unit for heating and ventilation)

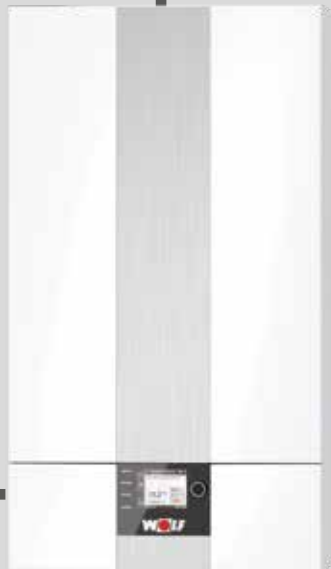

2-wire eBUS connection

### AM display module or BM-2 programming unit; an essential requirement



BM-2 programming unit in black or white (if BM-2 is inside the heat generator, max. 6 additional remote controls are possible)



2-wire eBUS connection



**MM-2 mixer module**

- Extension module to control one circuit with mixer
- Weather-compensated flow temperature control
- Easy controller configuration by selecting one of the preset system versions
- BM-2 programming unit with wall mounting base can be extended to serve as a remote control
- Rast 5 connection technology
- Incl. flow temperature sensor

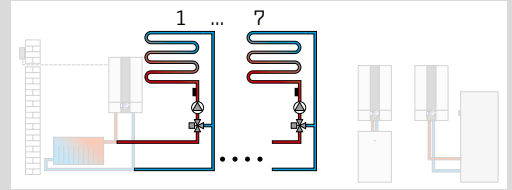

**SM1-2 solar module**

- Extension module to control one solar circuit incl. collector temperature sensor, cylinder temperature sensor and sensor wells
- In conjunction with WOLF heat generators, greater energy savings through intelligent cylinder reheating, i.e. blocking cylinder reheating when there is sufficient solar energy
- Heat metering with external heat meter
- Function check for flow rate and gravity brake
- Temperature differential control for one heat consumer
- Maximum cylinder temperature limit
- Indication of set and actual values on the BM-2 programming unit
- Integral hours run meter
- eBUS interface with automatic energy management
- Rast 5 connection technology
- Part of the standard delivery for CSZ-2

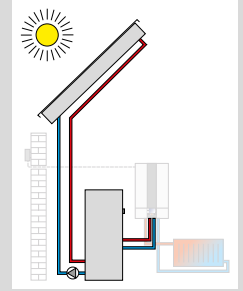

**SM2-2 solar module**

- Extension module to control one solar thermal system with up to 2 cylinders and 2 collector arrays, incl. 1 collector sensor and 1 cylinder sensor, each with sensor well
- Easy controller configuration by selecting one of the preset system versions
- In conjunction with WOLF heat generators, greater energy savings through intelligent cylinder reheating, i.e. blocking cylinder reheating when there is sufficient solar energy
- Heat metering with external heat meter for all configurations
- Selection of cylinder operating mode
- Indication of set and actual values on the BM-2 programming unit
- eBUS interface with automatic energy management
- Rast 5 connection technology

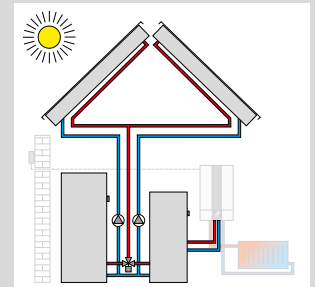

**KM-2 cascade module**

- Extension module to control systems with a low loss header or cascade operation
- Suitable for wall mounted gas condensing boilers (4 appliances)
- Easy controller configuration by selecting one of the preset system versions
- Switching of one heating circuit with mixer
- BM-2 programming unit slots into wall mounting base and can be extended to serve as a remote control
- 0-10 V input for BMS systems; 230 V fault message output
- eBUS interface with automatic energy management
- Rast 5 connection technology

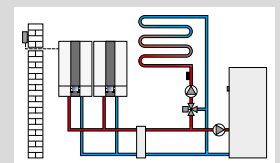

2-wire eBUS connection



Wireless outside temperature sensor  
[only in conjunction with receiver for wireless outside temperature sensor and remote control, part no. 27 44 209]



Wireless receiver for wireless outside temperature sensor and wireless remote control  
incl. radio clock (DCF77 signal)

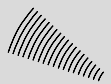

Wireless remote control  
[only in conjunction with receiver for wireless outside temperature sensor and remote control]  
Max. one wireless remote control per circuit with mixer.



AFB analogue remote control

- Simple WRS remote control for heating circuits and circuits with mixer
- Each heating circuit can be operated separately with a remote control
- Integral room temperature sensor
- Temperature and program selection via rotary selector
- Only in conjunction with BM-2 programming unit



**RM-2 room module**

4 in 1: Automatic detection of the function based on the system components:

- Room temperature controller with 1-day / 7-day program
- Remote control for mechanical ventilation unit CWL Excellent / CWL 2 [simultaneous with room temperature control]
- Remote control of all heating or mixing circuits [with BM/BM-2 in the system]
- Remote control for up to 7 individual heating circuits with multiple RM-2 units [with BM/BM-2 in the system]

- Illuminated touchscreen
- Integrated room temperature sensor
- Connection via eBus interface
- Many functions: Holiday mode, fault messages, temperature displays, etc.
- Compatible with WOLF Smartset



ISM8i Ethernet interface module

Interface module with disclosed TCP/IP protocol for system-independent integration of WOLF heating appliances and ventilation units.



KNX interface set

Interface set for integration of WOLF heat generators into a KNX network

Comprising:  
ISM8i interface module, KNX-IP-BAOS module,  
installation/operating instructions, network cable



I/O module

Extension module for 2 programmable inputs and outputs

**WOLF LINK HOME**

LAN / WLAN interface for accessing the control unit via the internet or a local network. Operation via iOS, Android or the WOLF portal. Installation in the appliance control unit.

2-wire eBUS connection

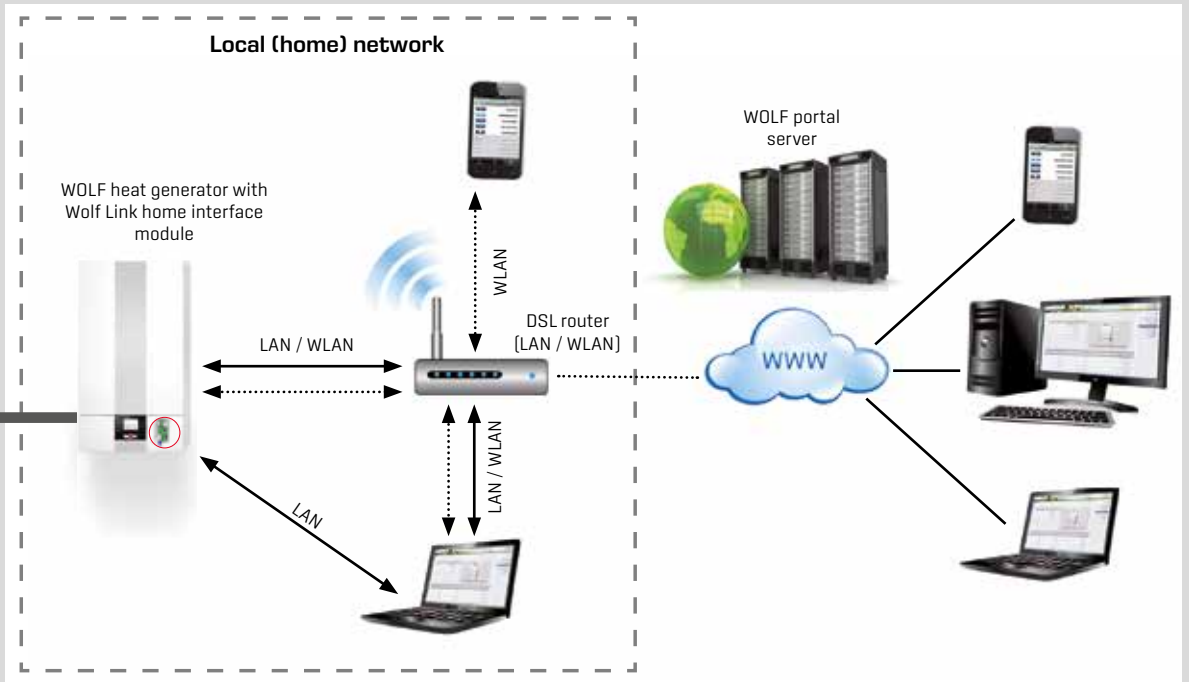

Wolf Link home enables WOLF heat generators to be integrated into the SmartHome system from "wibutler". In combination with the Smart Home system provider's room sensors and thermostats, the set enables demand-driven individual room temperature control via flow temperature adaptation based on the actual heat demand of the occupants and the structural conditions of the house. At the same time, the SmartHome set enables contractors to carry out remote maintenance and diagnostics via the WOLF internet portal.

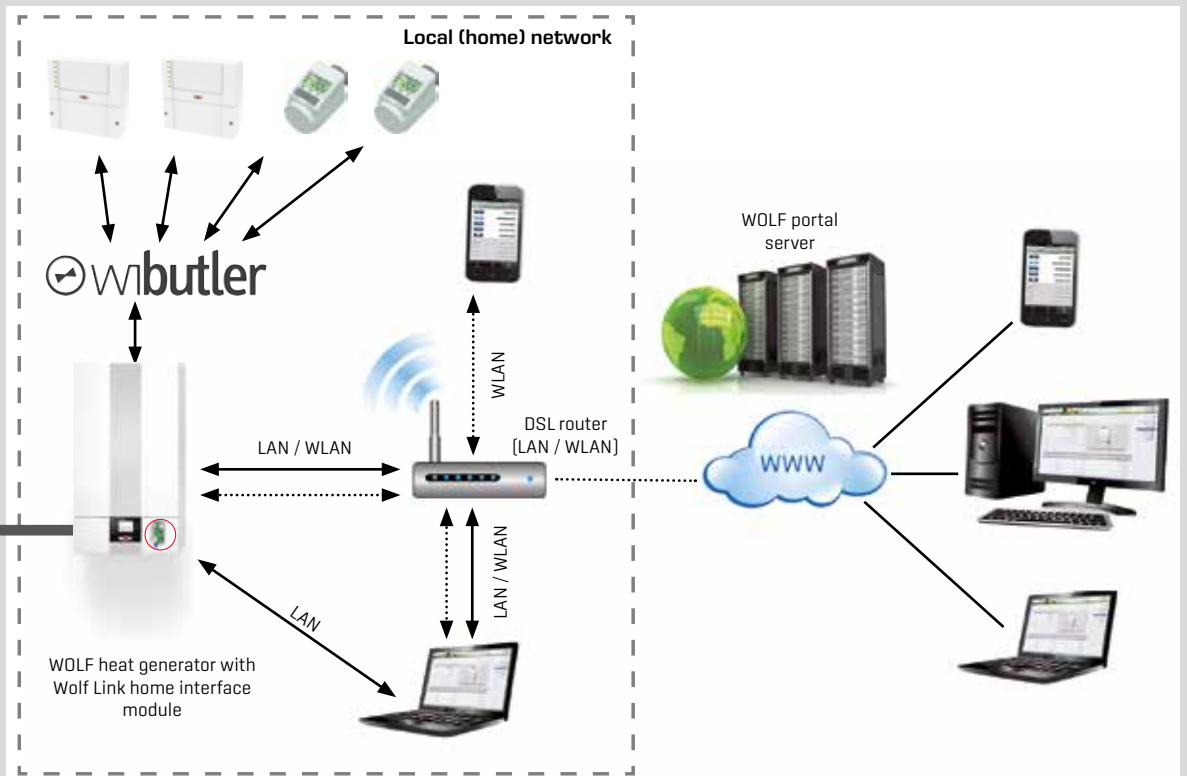

# AIR/FLUE GAS ROUTING FOR WALL MOUNTED GAS CONDENSING BOILERS CGB-2(K) / CGW-2 / CGS-2 / CSZ-2

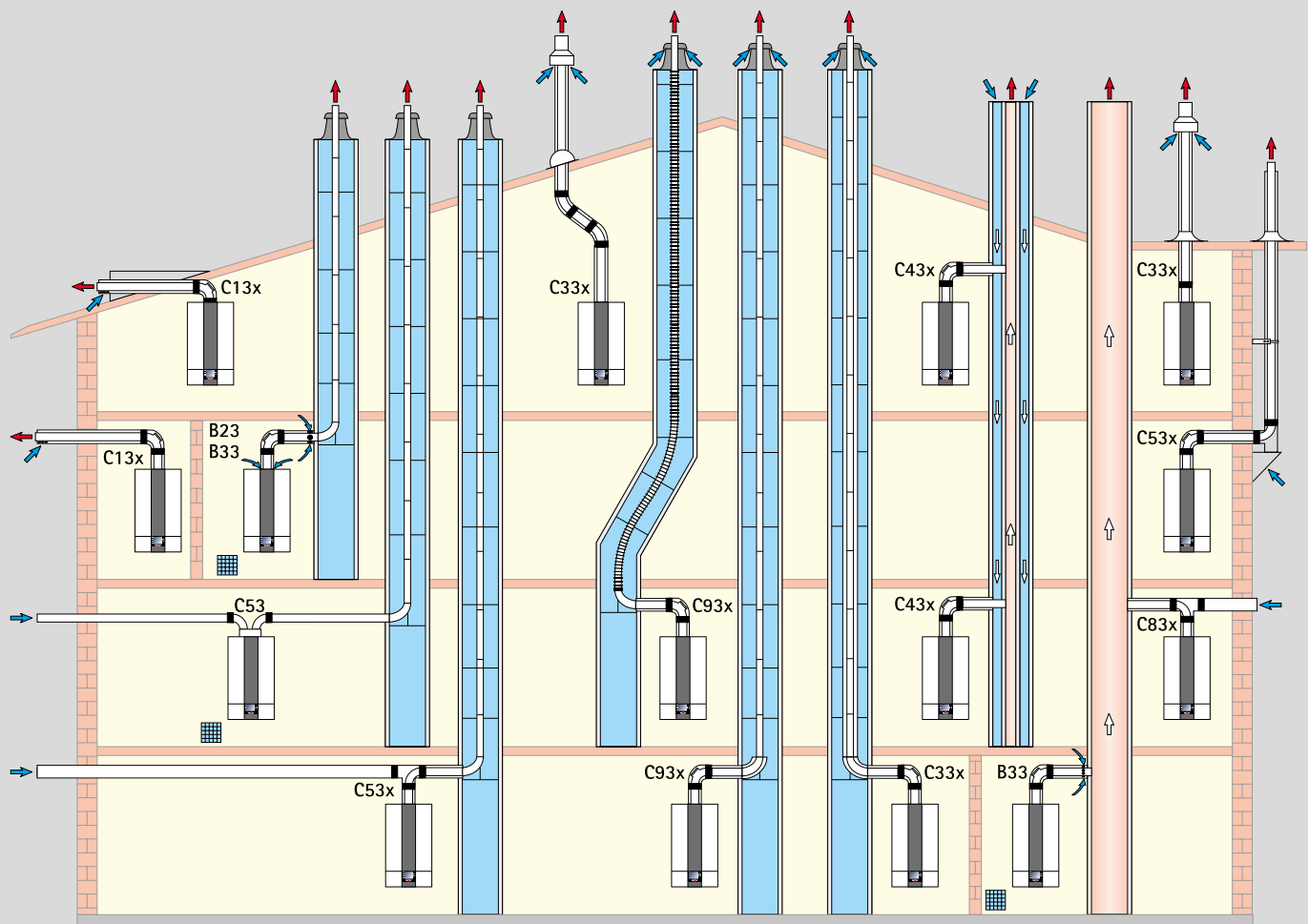

 Provide ventilation for B23, B33, C53

# AIR/FLUE GAS ROUTING FOR WALL MOUNTED GAS CONDENSING BOILERS CGB-2(K) / CGW-2 / CGS-2 / CSZ-2

Design variants		Maximum length <sup>1)</sup> [m]			
		CGB-2-14 CGW-2-14 CGS-2-14 CSZ-2-14	CGB-2(K)-20 CGW-2-20 CGS-2-20 CSZ-2-20	CGB-2(K)-24 CGW-2-24 CGS-2-24 CSZ-2-24	
B23	Flue pipe in a shaft and combustion air directly via the appliance (open flue)	DN 60	45	25	21
		DN 80	-	50	50
B33	Flue pipe in a shaft with horizontal concentric connection pipe (open flue)	DN 60	43	23	19
		DN 80	50	50	50
B33	Connection to a moisture-resistant flue gas chimney with a horizontal concentric connection pipe (open flue)	Calculation to EN 13384 (balanced flue chimney manufacturer)			
C13x	Horizontal roof outlet through a pitched roof (room sealed - on-site dormer)	DN 60/100	10	10	10
		DN 80/125	10	10	10
		DN 60/100	16	14	12
C33x	Vertical concentric roof outlet through pitched or flat roof, vertical concentric balanced flue system for installation in a shaft (room sealed)	DN 80/125	17	22	26
		DN 110/160	18	25	30
		Calculation to EN 13384 (balanced flue chimney manufacturer)			
C43x	Connection to a moisture-resistant balanced flue chimney, maximum pipe length from centre of boiler bend to connection 2 m (room sealed)	Calculation to EN 13384 (balanced flue chimney manufacturer)			
C53	Connection to flue in a shaft and ventilation air supply through external wall (room sealed), 3 m ventilation air pipe incl.	DN 80/125	50	50	50
C53x	Connection to flue routed over an external wall, combustion air intake via external wall (room sealed)	DN 60/100	46	24	20
		DN 80/125	-	50	50
C83x	Connection to flue in a shaft and ventilation air through external wall (room sealed)	DN 80/125	50	50	50
C83x	Concentric connection to moisture-resistant flue gas chimney and combustion air through external wall (room sealed)	Calculation to EN 13384 (balanced flue chimney manufacturer)			
C93x	Flue pipe for installation in a shaft Connection pipe DN 60/100, vertical DN 60	rigid	17	17	17
		flexible	13	13	13
C93x	Flue pipe for installation in a shaft Connection pipe DN 60/100 or DN 80/125, vertical DN 80	rigid	18	21	26
		flexible	14	17	22

<sup>1)</sup> The maximum length refers to the total length from the appliance to the flue terminal

**Note: Systems C33x and C83x are also suitable for installation in garages.**

The calculation was made taking the pressure conditions into account (geodetic height: 325 m).

Where necessary, adapt the installation examples to the relevant building regulations and requirements in your country/region. Any questions relating to the installation, particularly regarding the provision of inspection components and ventilation apertures (ventilation generally required above 50 kW output) should be raised with your local flue gas inspector prior to installation.

**The specified lengths refer to concentric balanced flues and standard flues, and apply to original WOLF components only.**

### Calculating the length of the air/flue gas routing

The calculated length of the balanced flue or standard flue is derived from the straight pipe length and the length equivalent of any pipe bends.

#### Example:

Length of straight balanced flue pipe = 1.5 m

87° bend = 2.0 m

2 x 45° bends = 2 x 1.2 m

L = 1.5 m + 1 x 2.0 m + 2 x 1.2 m

L = 5.9 m

**Balanced flue systems DN 60/100, DN 80/125 and DN 110/160 are certified as systems together with WOLF wall mounted gas condensing boilers.**

The following balanced flues or standard flues with CE-0036-CPD-9169003 certification may be used:

- Flue DN 60, DN 80, DN 110, DN 125 and DN 160
- Concentric balanced flue DN 60/100, DN 80/125 and DN 110/160
- Concentric balanced flue (on an external wall) DN 80/125
- Flexible flue DN 60, DN 80 and DN 110

WOLF accessories are supplied with the necessary identification labels. Please also observe the installation information supplied with the accessories.

Bend	Type	Calculated length [m]
30°	Single wall	0.4
45°	Single wall	0.6
87°	Single wall	1.0
30°	Concentric	0.7
45°	Concentric	1.2
87°	Concentric	2.0

# COMFORTLINE WALL MOUNTED GAS CONDENSING BOILERS ACCESSORIES

**CGB-2** Wall mounted gas condensing boiler for central heating with option to connect a DHW cylinder

**CGB-2K** Wall mounted gas condensing boiler for DHW and central heating

**CGW-2** Gas condensing centre for DHW and central heating with wall mounted stainless steel stratification cylinder

**CGS-2L** Gas condensing centre for DHW and central heating with enamelled steel stratification cylinder

**CGS-2R** Gas condensing centre for DHW and central heating with enamelled steel DHW cylinder with indirect coil

**CSZ-2** Gas condensing solar centre in modular form for DHW and central heating

Tested in accordance with EC directives and EN 483 for heating systems according to EN 12828 with flow temperatures up to 90 °C and 3 bar permissible operating pressure. Suitable for modulating operation down to room temperature; modulating output control; gas-adaptive, self-calibrating combustion controller for extremely clean combustion and fluctuating gas qualities. Premix burner suitable for natural gas E, LL or LPG; sealed combustion chamber for open flue and room sealed operation.

Control unit with gas burner control unit, electronic ignition and ionisation flame monitor; variable speed fan.

White RAL 9016 powder-coated casing.

	<b>CGB-2</b>	<b>CGB-2</b>	<b>CGB-2K</b>	<b>CGW-2</b>	<b>CGS-2</b>	<b>CGS-2</b>	<b>CSZ-2</b>
	-14	<b>with</b>	-20	-14/100L	-14/120L	-14/150R	-14/300R
	-20	<b>CSW-120</b>	-24	-20/120L	-20/160L	-20/150R	-20/300R
	-24			-24/140L	-24/200L	-24/150R	-24/300R

## Accessories

Control accessories	<b>CGB-2</b>	<b>CGB-2</b>	<b>CGB-2K</b>	<b>CGW-2</b>	<b>CGS-2</b>	<b>CGS-2</b>	<b>CSZ-2</b>
AM display module	○	○	○	○	○	○	○
BM-2 programming unit	○	○	○	○	○	○	●
Wall mounting base	○	○	○	○	○	○	○
AFB analogue remote control	○	○	○	○	○	○	○
RM-2 room module	○	○	○	○	○	○	○
MM-2 mixer module	○	○	○	○	○	○	○
SM1-2 solar module	○	○	○	○	○	○	●
SM2-2 solar module	○	○	○	○	○	○	
KM-2 cascade module	○						
Heat meter set for capturing solar yield							○
Wireless receiver for wireless outside temperature sensor and wireless remote control incl. radio clock (DCF77 signal)	○	○	○	○	○	○	○
Wireless outside temperature sensor	○	○	○	○	○	○	○
Wireless remote control	○	○	○	○	○	○	○
WOLF Link home / pro - LAN/WLAN interface module incl. PC software	○	○	○	○	○	○	○

● Included in standard delivery

○ Optional accessory

# COMFORTLINE WALL MOUNTED GAS CONDENSING BOILERS ACCESSORIES

	CGB-2	CGB-2 with CSW-120	CGB-2K	CGW-2	CGS-2	CGS-2	CSZ-2
	-14		-20	-14/100L	-14/120L	-14/150R	-14/300R
	-20		-24	-20/120L	-20/160L	-20/150R	-20/300R
	-24			-24/140L	-24/200L	-24/150R	-24/300R

## Accessories

### Hydraulic accessories and gas supply accessories

Gas ball valve (angle or straight-through version), chrome plated, with thermally activated shut-off valve

○   ○   ○   ○   ○   ○   ●

Safety valve Rp $\frac{1}{2}$ " up to 3 bar

○   ○   ○   ○   ○   ○   ●

Drain outlet kit R1" with trap and bezel, grey plastic

○   ○   ○   ○   ○   ○   ●

Filling device

○   ○   ○

### Accessories for concealed installation

Angle maintenance valve G $\frac{3}{4}$ ", chrome plated

○   ○   ○   ○   ○   ○

Angle maintenance valve G $\frac{3}{4}$ " with connection R $\frac{1}{2}$ " for safety valve, chrome plated

○   ○   ○   ○   ○   ○

DHW connector G $\frac{1}{2}$ ", chrome plated

○   ○

Cold water connector G $\frac{1}{2}$ ", chrome plated

○   ○

Connection set for concealed installation

○   ○   ○   ○   ○   ○

DHW connection set with or without pressure reducer

○

### Accessories for surface mounting

Straight-through maintenance valve Rp $\frac{3}{4}$ ", chrome plated

○   ○   ○   ○   ○   ○

Straight-through maintenance valve Rp $\frac{3}{4}$ " with connection R $\frac{1}{2}$ " for safety valve, chrome plated

○   ○   ○   ○   ○   ○

DHW connector R $\frac{1}{2}$ ", chrome plated

○   ○

Cold water connector R $\frac{1}{2}$ ", chrome plated

○   ○

Connection set for surface mounting

○   ○   ○   ○   ○   ○

Pre-assembled connection set for surface mounting

○   ○

DHW connection set with or without pressure reducer

○

- Included in standard delivery
- Optional accessory

# COMFORTLINE WALL MOUNTED GAS CONDENSING BOILERS ACCESSORIES

	CGB-2	CGB-2	CGB-2K	CGW-2	CGS-2	CGS-2	CSZ-2
	-14	with	-20	-14/100L	-14/120L	-14/150R	-14/300R
	-20	CSW-120	-24	-20/120L	-20/160L	-20/150R	-20/300R
	-24			-24/140L	-24/200L	-24/150R	-24/300R

## Accessories

### Accessories for connection sets

Solar heating connection set for the additional control of a solar cylinder

Set for solar integration

Partially pre-assembled gas condensing centre pipework connection set for connection to heating flow/return, DHW/cold water, gas

Flow and return connection set for heating and solar circuit and gas supply

DHW/cold water connection set with thermostatic water mixer and high efficiency DHW circulation pump

### DHW circulation accessories

High efficiency DHW circulation pump

### Other accessories

Pipe cladding

Height-adjustable support platform for unfinished floors

Impressed current anode

Solar heat meter set

### CSW-120 DHW cylinder

### Balanced flue accessories

Concentric balanced flue

External wall system

Flue system connection set for flues in a shaft

● Included in standard delivery

○ Optional accessory





# NOTES

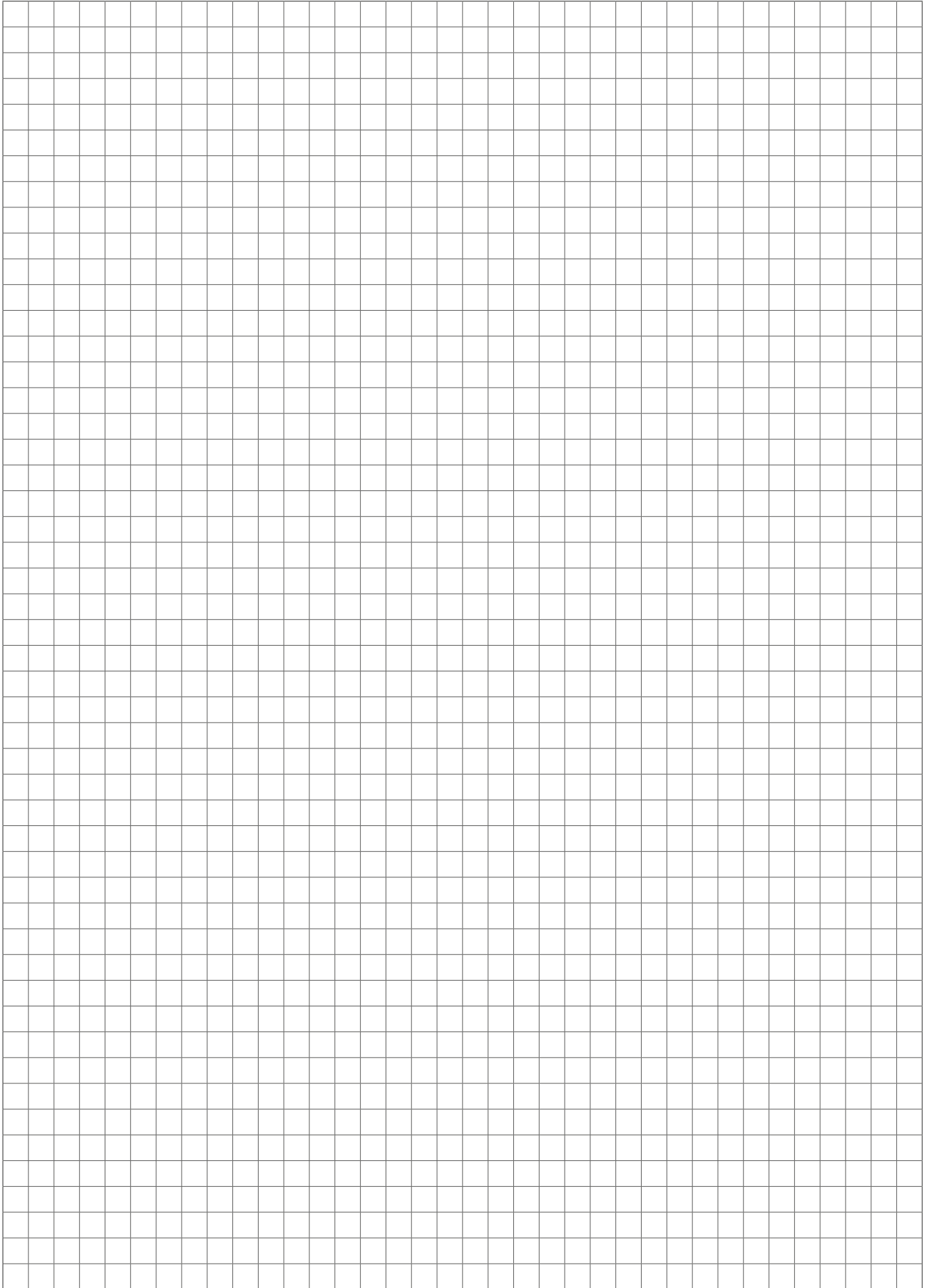



Dealer address

WOLF GMBH / P.O. BOX 1380 / D-84048 MAINBURG / TEL. +49.0.875174-0 / FAX +49.0.875174-1600 / www.WOLF.eu

